



# GIMA

PROFESSIONAL MEDICAL PRODUCTS

## GIMA VITAL SIGNS MONITORS VITAL PRO-SNET

**REF**

**PC-900PRO(SNET) (35124)**



Shenzhen Creative Industry Co., Ltd.  
Floor 5, BLD 9, BaiWangxin High-Tech Industrial Park,  
Songbai Road, Xili Street, Nanshan District,  
518110 Shenzhen, P.R. China  
Made in China

**EC REP**

Shanghai International Holding Corp. GmbH (Europe)  
Eiffestr. 80, 20537 Hamburg - Germany

Imported by:

**Gima S.p.A.**

Via Marconi, 1 - 20060 Gessate (MI) Italy  
gima@gimaitaly.com - export@gimaitaly.com  
[www.gimaitaly.com](http://www.gimaitaly.com)



0123



---

This Manual is written and compiled in accordance with the IEC 60601-1 (Medical electrical equipment Part1: General requirements for safety) and MDD 93/42/EEC. It complies with both international and enterprise standards and is also approved by State Technological Supervision Bureau. The Manual is written for the current Vital Signs Monitor.

The Manual describes, in accordance with the Vital Signs Monitor's features and requirements, main structure, functions, specifications, correct methods for transportation, installation, usage, operation, repair, maintenance and storage, etc. as well as the safety procedures to protect both the user and equipment. Refer to the respective chapters for details.

The Manual is published in English and we have the ultimate right to explain the Manual. No part of this manual may be photocopied, reproduced or translated into another language without the prior written consent. We reserve the right to improve and amend it any time without prior notice. Amendments will however be published in a new edition of this manual.

Version of This Manual: Ver 2.0

Revised Date: April 21, 2021

Manufactured date: See label on device

Service life: 5 years

All rights reserved.

Marks in the Manual:

 **Caution: must be followed to avoid endangering the operator and the patient.**

 **Attention: must be followed to avoid causing damage to the monitor.**

 **Note: some important information and tips about operations and application.**

3502-2530007

---

# Instructions to User

Dear Users,

Thank you very much for purchasing our product. Please read the following information very carefully before using this device.

Read these instructions carefully before using this monitor. These instructions describe the operating procedures to be followed strictly. Failure to follow these instructions can cause monitoring abnormality, equipment damage and personal injury. The manufacturer is NOT responsible for the safety, reliability and performance issues and any monitoring abnormality, personal injury and equipment damage due to user's negligence of the operation instructions. The manufacturer's warranty service does not cover such faults.

- ⚠ **WARNING-PACEMAKER PATIENTS.** This monitor may continue to count the pacemaker rate during occurrences of cardiac arrest or some arrhythmias. Do not rely entirely upon this monitor ALARMS. Keep pacemaker patients under close surveillance.
- ⚠ **Monitoring a single person at a time.**
- ⚠ **The monitor is defibrillator proof. Verify that the accessories can function safely and normally and the monitor is grounded properly before conducting defibrillation.**
- ⚠ **Disconnect the monitor and sensors before MRI scanning. Use during MRI could cause burns or adversely affect the MRI image or the monitor's accuracy.**
- ⚠ **If you have any doubt to the grounding layout and its performance, you must use the built-in battery to power the monitor.**
- ⚠ **All combinations of equipment must be in compliance with standard of IEC 60601-1-1 for medical electric system requirements.**
- ⚠ **Check SpO<sub>2</sub> probe application site periodically (every 30 minutes) to determine circulation, positioning and skin sensitivity.**
- ⚠ **The SpO<sub>2</sub> probe of this monitor may not work for all testees. If stable readings can not be obtained at any time, change appropriate probe or discontinue use of SpO<sub>2</sub> monitoring.**
- ⚠ **Do not immerse the monitor or its accessories in liquid to clean.**
- ⚠ **Do not use accessories other than those provided/recommended by the manufacturer.**
- ⚠ **Each time the monitor is used, check the alarm limits to ensure that they are appropriate for the patient being monitored.**
- ⚠ **The monitor is intended only as an adjunct in patient assessment. It must be used in conjunction with clinical signs and symptoms.**
- ⚠ **When taking the measure of an pediatric or neonate's (less than 10 years old) blood pressure, do NOT operate in the adult mode. The high inflation pressure may cause lesion or even body putrescence.**
- ⚠ **The monitor is prohibited from applying to those who have severe hemorrhagic tendency or who are with sickle cell disease for they may develop partial bleeding when this monitor is used to take the blood pressure measurement.**

- 
- ☼ **DO NOT take blood pressure measurement from a limb receiving ongoing transfusion or intubation or skin lesion area, otherwise, damages may be caused to the limb.**
  - ☼ **Continuous use of SpO<sub>2</sub> sensor may result in discomfort or pain, especially for those with micro-circulatory problem. It is recommended that the sensor should NOT be applied to the same place for over two hours, change the measuring site periodically if necessary.**
  - ☼ **SpO<sub>2</sub> measuring position must be examined more carefully for some special patient. Do NOT install the SpO<sub>2</sub> sensor on the finger with edema or vulnerable tissue.**
  - ☼ **To prevent the risk of the short circuit and to ensure the ECG signal quality, the equipment must be properly grounded.**
  - ☼ **Although biocompatibility tests have been performed on all the applied parts, some exceptional allergic patients may still have anaphylaxis. Do NOT apply to those who have anaphylaxis.**
  - ☼ **All the connecting cables and rubber tubes of the applying parts should be kept away from the patient's cervix to prevent any possible suffocation of the patient.**
  - ☼ **All the parts of the monitor should NOT be replaced at will. If necessary, please use the components provided by the manufacturer or those that are of the same model and standards as the accessories along with the monitor which are provided by the same factory, otherwise, negative effects concerning safety and biocompatibility etc. may be caused.**
  - ☼ **DO NOT stare at the infrared light of SpO<sub>2</sub> sensor when switch it on, for the infrared may do harm to the eye.**
  - ☼ **If the monitor falls off accidentally, please do NOT operate it before its safety and technical indexes have been tested minutely and positive testing results obtained.**
  - ☼ **It is recommended to take the blood pressure measurement manually. The automatic or continuous mode should be used at the presence of a doctor/nurse.**
  - ☼ **Alarm limits should not be set to exceed the measuring range, or the alarm system will not generate alarm signals because of no alarm condition. Refer to the Technical Specification for detailed measuring range.**
  - ☼ **Please peruse the relative content about the clinical restrictions and contraindication.**
  - ☼ **When disposing of the monitor and its accessories, the local law should be followed.**
  - ☼ **Do not replace the built-in battery when the device is at working state.**



---

# Table of Contents

|  |    |
|--|----|
| Chapter 1 Overview.....                                    | 1  |
| 1.1 Features.....  | 1  |
| 1.2 Product Name and Model.....                            | 1  |
| 1.3 Intended Use.....                                      | 1  |
| 1.4 Safety.....  | 1  |
| Chapter 2 Operating Principle.....                         | 2  |
| 2.1 Overall Structure.....                                 | 2  |
| 2.2 Conformation.....                                      | 2  |
| Chapter 3 Installation and Connection.....                 | 3  |
| 3.1 Appearance.....  | 3  |
| 3.1.1 Front Panel.....                                     | 3  |
| 3.1.2 Side Panel.....                                      | 5  |
| 3.1.3 Rear Panel.....                                      | 6  |
| 3.1.4 Underside of the Monitor.....                        | 7  |
| 3.2 Battery Installation.....                              | 7  |
| 3.3 Installation.....                                      | 8  |
| 3.3.1 Opening the Package and Check.....                   | 9  |
| 3.3.2 Connecting the Power Supply.....                     | 9  |
| 3.3.3 Starting the Monitor.....                            | 9  |
| 3.4 Sensor Placement and Connection.....                   | 9  |
| 3.4.1 ECG Cable Connection.....                            | 9  |
| 3.4.2 Blood Pressure Cuff Connection.....                  | 12 |
| 3.4.3 SpO <sub>2</sub> Sensor Connection.....              | 15 |
| 3.4.4 TEMP Transducer Connection.....                      | 16 |
| 3.4.5 Loading printer paper (if printer is installed)..... | 17 |
| Chapter 4 Operations.....                                  | 20 |
| 4.1 Initial Monitoring Screen.....                         | 20 |
| 4.2 Default Screen.....                                    | 20 |
| 4.3 Screen for Real-time ECG waveform Only (Optional)..... | 23 |
| 4.4 Screen Display for ECG Waveform Recall (Optional)..... | 24 |
| 4.5 NIBP List Screen (Optional).....                       | 25 |
| 4.6 SpO <sub>2</sub> Data List Screen (Optional).....      | 25 |
| 4.7 Alarm Event List Screen.....                           | 26 |
| 4.8 Trend Graph Display (for SpO <sub>2</sub> Option)..... | 27 |
| 4.9 Setup Menu Screen.....                                 | 28 |
| 4.9.1 ECG Setup (Optional).....                            | 29 |
| 4.9.2 SpO <sub>2</sub> Setup (Optional).....               | 30 |
| 4.9.3 NIBP Setup (Optional).....                           | 31 |
| 4.9.4 TEMP Setup (Optional).....                           | 34 |
| 4.9.5 Hemostat Setup (Optional).....                       | 34 |
| 4.9.6 Patient Info.....                                    | 35 |
| 4.9.7 Date/Time Setup.....                                 | 36 |
| 4.9.8 Nurse Call Setup.....                                | 36 |
| 4.9.9 Network Setup (Optional).....                        | 37 |
| 4.9.10 System Setup.....                                   | 38 |
| 4.9.11 Reset to Factory Default Settings.....              | 39 |
| 4.9.12 About.....  | 39 |
| 4.10 Alarm Settings.....                                   | 40 |
| 4.11 Data Uploading.....                                   | 40 |
| Chapter 5 Alarms.....                                      | 41 |
| 5.1 Alarm Priority.....                                    | 41 |
| 5.2 Alarm Signal Generation.....                           | 42 |
| 5.3 Alarm Reset and Silence.....                           | 43 |
| 5.4 Alarm Settings.....                                    | 43 |
| 5.5 Verifying Alarm Function.....                          | 44 |
| Chapter 6 Technical Specifications.....                    | 45 |
| 6.1 ECG Monitoring.....                                    | 45 |

---

---

|   |    |
|---|----|
| 6.2 TEMP Monitoring.....  | 46 |
| 6.3 NIBP Monitoring.....  | 46 |
| 6.4 SpO <sub>2</sub> Monitoring.....  | 46 |
| 6.5 Pulse Rate monitoring.....  | 46 |
| 6.6 Data Recording.....   | 46 |
| 6.7 Other Technical Specifications.....   | 47 |
| 6.8 Operating Environment.....  | 47 |
| 6.9 Classification.....   | 47 |
| 6.10 Other Technical Information.....   | 47 |
| 6.10.1 Additional description for ECG monitoring.....                             | 47 |
| 6.10.2 Additional description for SpO <sub>2</sub> monitoring.....                | 48 |
| 6.10.3 Additional description for NIBP measurement.....                           | 48 |
| 6.10.4 Additional description for temperature measurement.....                    | 48 |
| 6.10.5 Additional description for alarm system.....                               | 48 |
| 6.10.6 Additional description for power supply, network and display.....          | 49 |
| 6.11 Guidance and manufacturer's declaration – Electromagnetic compatibility..... | 50 |
| Chapter 7 Packaging and Accessories.....  | 54 |
| 7.1 Packaging.....  | 54 |
| 7.2 Accessories Supplied.....   | 54 |
| Chapter 8 Monitoring Parameter.....   | 55 |
| 8.1 ECG Monitoring.....   | 55 |
| 8.1.1 How to Obtain High Quality ECG and Accurate Heart Rate Value.....           | 55 |
| 8.1.2 Factors affecting ECG signal.....   | 55 |
| 8.2 NIBP Monitoring.....  | 56 |
| 8.2.1 Measuring Principle.....  | 56 |
| 8.2.2 Factors affecting NIBP measuring.....                                       | 57 |
| 8.2.3 Clinical Limitations and Contraindications.....                             | 57 |
| 8.3 SpO <sub>2</sub> Monitoring.....  | 58 |
| 8.3.1 Measuring Principle.....  | 58 |
| 8.3.2 Sources of interference for SpO <sub>2</sub> Measurement.....               | 58 |
| 8.3.3 Pathological reasons for low SpO <sub>2</sub> measurements.....             | 58 |
| 8.3.4 Clinical Limitations.....   | 58 |
| 8.3.5 Points to be noted in SpO <sub>2</sub> and Pulse Measuring.....             | 59 |
| 8.4 Temperature Monitoring (optional).....  | 59 |
| Chapter 9 Troubleshooting.....  | 60 |
| 9.1 No Display on the Screen.....   | 60 |
| 9.2 Excessive ECG Signal Interference or Too Thick Baseline.....                  | 60 |
| 9.3 No Blood Pressure and Pulse Oxygen Readings.....                              | 60 |
| 9.4 Blank Print-out.....  | 60 |
| 9.5 System Alarm.....   | 60 |
| Chapter 10 Maintenance.....   | 61 |
| 10.1 Service and Examination.....   | 61 |
| 10.1.1 Daily Examination.....   | 61 |
| 10.1.2 Routine Maintenance.....   | 61 |
| 10.1.3 Battery Maintenance.....   | 61 |
| 10.1.4 Service.....   | 62 |
| 10.2 Cleaning and Disinfection.....   | 62 |
| 10.3 Cleaning and Disinfection of Accessories.....                                | 62 |
| 10.4 Storage.....   | 63 |
| 10.5 Transportation.....  | 63 |
| Chapter 11 Appendix.....  | 64 |
| 11.1 Prompt information explanations.....   | 64 |
| 11.2 Factory Default Alarming Values and Setup Range.....                         | 65 |
| 11.3 Abbreviation of arrhythmia.....  | 66 |
| 11.4 Instructions for SpO <sub>2</sub> Probe.....                                 | 67 |

---

# Chapter 1 Overview

## 1.1 Features

- ✧ Blood Pressure, SpO<sub>2</sub>, and Pulse Rate or Heart Rate on large, bright LED display;
- ✧ Color LCD to display ECG waveform and plethysmogram;
- ✧ Accurate NIBP measurement with hardware and software over-pressure protection, hemostat function is also available by cuff;
- ✧ Unique oximetry technique ensures sensitive and accurate SpO<sub>2</sub> and pulse rate measurement, pitch tone function is also available;
- ✧ Up to 12000 groups of BP measurements can be stored in non-volatile memory and reviewed by list, the stored data can be uploaded to computer;
- ✧ Historic data records can be reviewed in waveform, list or trend graph;
- ✧ Multi-level audible & visible alarm function, nurse call output is available;
- ✧ Network function for connecting to Central Monitoring System;
- ✧ Support HL7 protocol
- ✧ Option of built-in printer to print out waveform, and text information.

Note: The monitor you purchased may not cover all the mentioned functions according to its configuration.

## 1.2 Product Name and Model

**Name:** GIMA VITAL PRO MONITOR - VITAL PRO-SNET

## 1.3 Intended Use

This Monitor is a multi-functional instrument designed for monitoring the vital physiological signs of adult and pediatric patients. With the functions of real-time recording and displaying parameters, such as non-invasive blood pressure, body temperature, functional oxygen saturation and so on, it allows comprehensive analysis of patient's physiological conditions.

This instrument is applicable for use in hospitals and clinical institutions and should be operated by qualified personnel only.

## 1.4 Safety

- a) This device conforms to the standard IEC 60601-1, with electric safety classification of Class I, BF and CF type of applied parts.
- b) This device is defibrillator proof and resistant to interference from electro-surgical units.
- c) This device has a cardiac pace-maker pulse inhibition function.
- d) DO NOT use this device while the patient is under MRI or CT scanning.

---

## Chapter 2 Operating Principle

### 2.1 Overall Structure

The overall structure of the monitor is shown in Fig. 2.1.

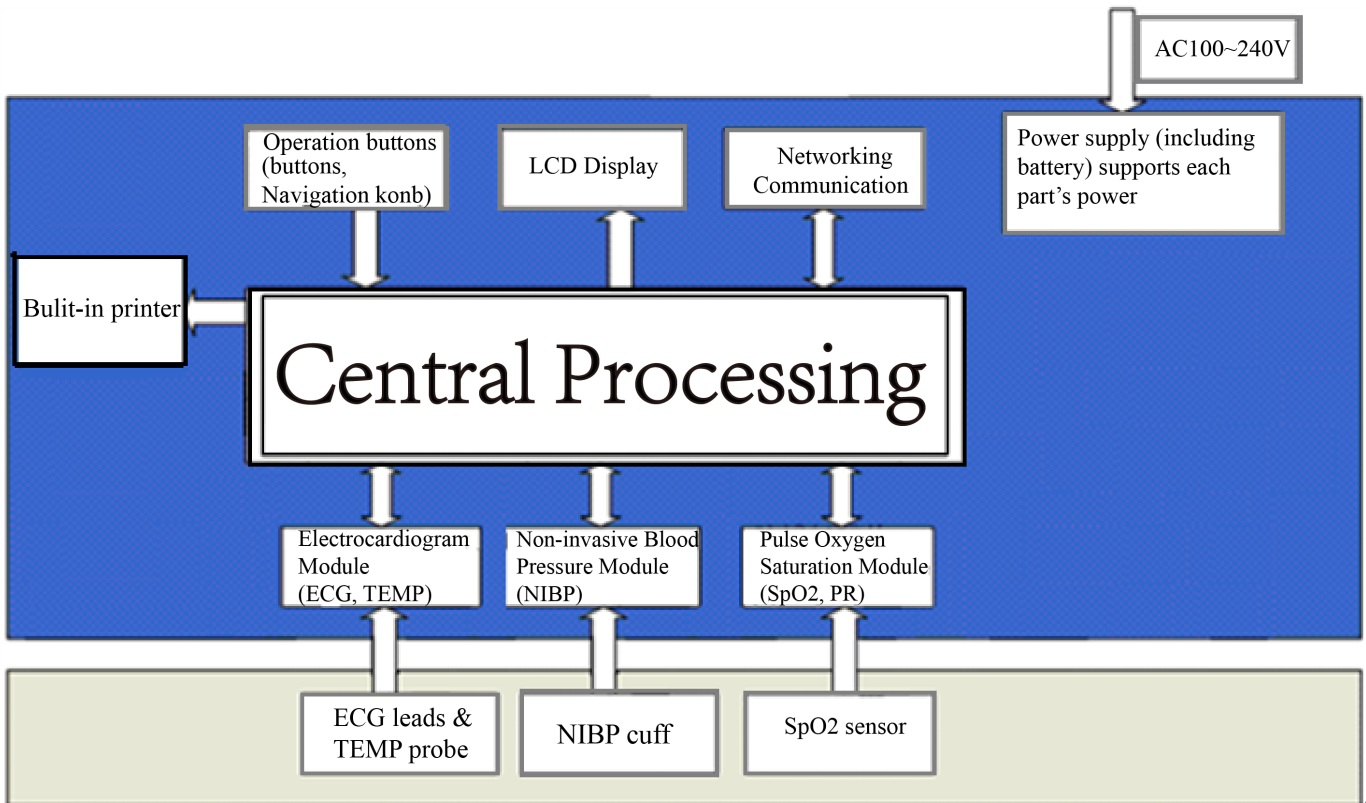

Figure 2.1

### 2.2 Conformation

The Gima Vital Pro Monitor is a product with modular design, consisting of an ECG module (Optional), NIBP module, SpO<sub>2</sub> module, temperature module, main control unit, printer module (Optional), display panel, and power supply module etc. and the related accessories for ECG, NIBP, SpO<sub>2</sub> and temperature measurement.

☞ According to user requirement, you can order the device with different configuration to include the necessary functions. Therefore, your monitor may not have all the monitoring functions and accessories.

1. The ECG/TEMP module detects the ECG signal through ECG cable/lead wires via electrodes. The temperature is measured through the temperature probe.
2. The SpO<sub>2</sub> module detects and calculates pulse rate and functional oxygen saturation (SpO<sub>2</sub>), and provides plethysmogram and perfusion index.
3. The NIBP module measures blood pressure non-invasively with way of oscillometric technology, including the diastolic, systolic and mean arterial pressure. The cuffs are designed for adult, pediatric and neonate respectively.
4. The main control unit is in charge of LED and LCD display, keyboard input, data storage, printing and networking function.

# Chapter 3 Installation and Connection

## 3.1 Appearance

### 3.1.1 Front Panel

The Gima Vital Pro Monitor with ECG function

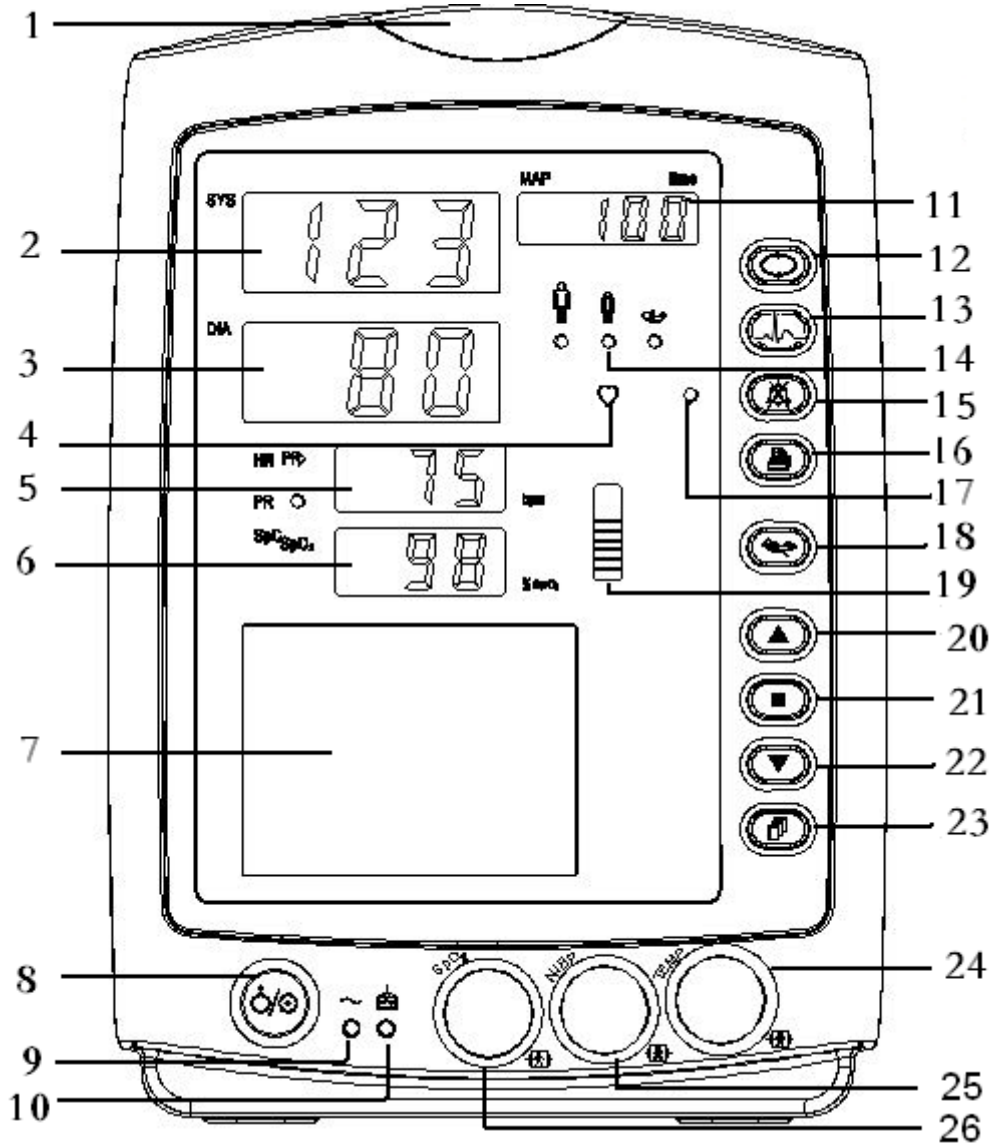

Figure 3.1B Front panel illustration for monitor (with ECG function)





#### Description:

1. "  "Alarm indicator

| Indicator<br>Color | Alarm Level           |
|--------------------|-----------------------|
| Red flashing       | High priority alarm   |
| Yellow flashing    | Medium priority alarm |
| Yellow light       | Low priority alarm    |
| Green light        | Normal                |

2. **SYS**: display of systolic pressure value.

3. **DIA**: display of diastolic pressure value.

4. : heart beat indicator.
5. **HR/PR**: display of heart rate / pulse rate; unit: bpm. Heart rate is priority to be displayed.
6. **SpO<sub>2</sub>**: display of SpO<sub>2</sub> value; Unit: “%”.
7. : **LCD panel**
8. : Power button: Long pressing power button to start or shut off the monitor; Short pressing to enter into or exit form power saving mode.
9. : AC Power indicator.
10. : DC Power indicator.

Description to AC, DC Power indicator:











|               | AC Power indicator | DC Power indicator | Descriptions   |
|---------------|--------------------|--------------------|--|
| <b>Status</b> | ON                 | ON                 | this device is on and using AC power supply                                    |
|               | OFF                | ON                 | the device is on and using built-in battery                                    |
|               | ON                 | OFF                | the device is off and battery is being charged while the AC power is connected |

**11. "MAP/Time"**: display mean arterial pressure at the end of a successful measurement and end time (in Manual or STAT mode) or counting down time (in Auto mode) alternatively. Cuff pressure is displayed during BP measurement or the hemostat function is in use.

There are 2 situations of display when the NIBP measurement finishes:

- 1) When NIBP measurement mode is set to “Manual” or “STAT”, the mean arterial pressure or measuring time will be displayed alternately, the time format is "hh:mm".
- 2) When NIBP measurement mode is set to “AUTO”, the counting down time will be displayed, the time format is "mm:ss". If the counting down time is over 1 hour, then it displays "hh:mm".

**Note:** BP value can be displayed in two units, “×××” mmHg” or “××.×” kPa, refer to section “4.9.3 NIBP Setup” to set the unit of BP value. The conversion between two units is: 1kPa=7.5 mmHg, 1mmHg=0.133kPa.

12.  **NIBP Setup key**: A shortcut key to change the NIBP measuring mode and cycle time for Auto mode.
13. : **ECG lead selection key**: A short press of this key to shift ECG lead, holding this key and pressing NIBP setup key (12) will lock or un-lock the key operation..
14. : **Patient category indicator**: “” for adult; “” for pediatric; “” for neonate.
15.  **Alarm silence key**.
16.  **Print**. The built-in printer is optional. If installed, press this key to print the current measured data.
17. : **Alarm silence indicator**. When it is on, it indicates that the alarm is silenced.
18.  **NIBP**: press to start/cancel NIBP measurement.
19. : Bar-graph of pulse intensity.

20. "▲" **Up:** shifts cursor forward/upward

21. "■" **OK:** In setting menu, press it to confirm selection or modification; On history record screen, long pressing this key to open up delete data dialogue box; On monitoring screen, short press to freeze/unfreeze ECG waveform.

22. "▼" **Down:** shifts cursor backward/downward.

23. "⏪" **Display View key:** short press to scroll through LCD display views or return to the upper level screen; long press to enter into root setting menu display screen.

24. **TEMP:** TEMP probe connector.

25. **NIBP:** NIBP hose connector.

26. **SpO<sub>2</sub>:** SpO<sub>2</sub> sensor connector.

Note: A long press would mean press and hold for 2 seconds.

### 3.1.2 Side Panel

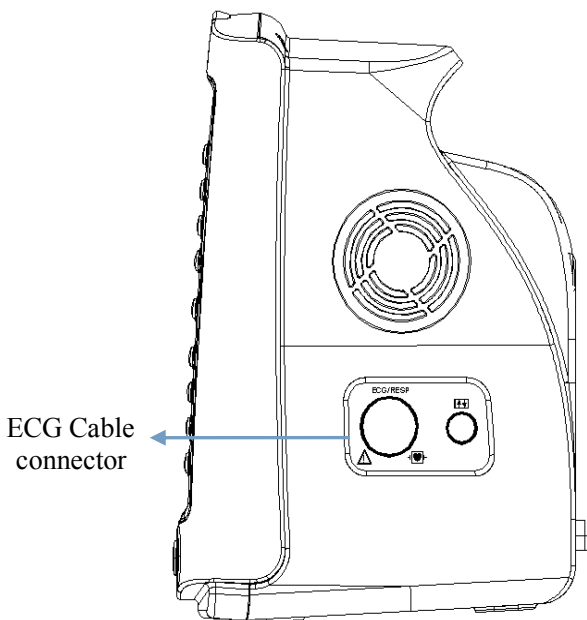

Figure 3.2 Right side of the monitor

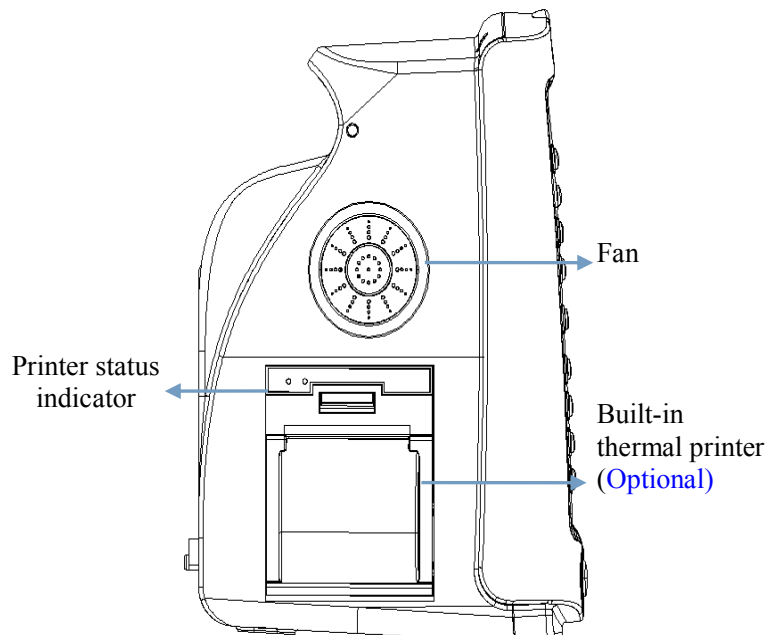



Figure 3.3 Left side of the monitor

The right panel of the monitor is as shown in figure 3.2.

- ◇  Symbol for CF type applied part with defibrillation-proof.
- ◇ ECG: ECG cable connector (Optional).
- ◇ "O": reserved port for future use.

The left panel of the monitor is as shown in figure 3.3.

The built-in thermal printer is in the left panel. It is easy for user to print waveform and data if this is installed.

- ◇ : printer status indicator. One is for power indication of the printer, the green light shows the power is on, while the monitor is shut down, the green light is off. The other is for error indication, when the paper is empty or the printer is out of order, the red light is on.

### 3.1.3 Rear Panel

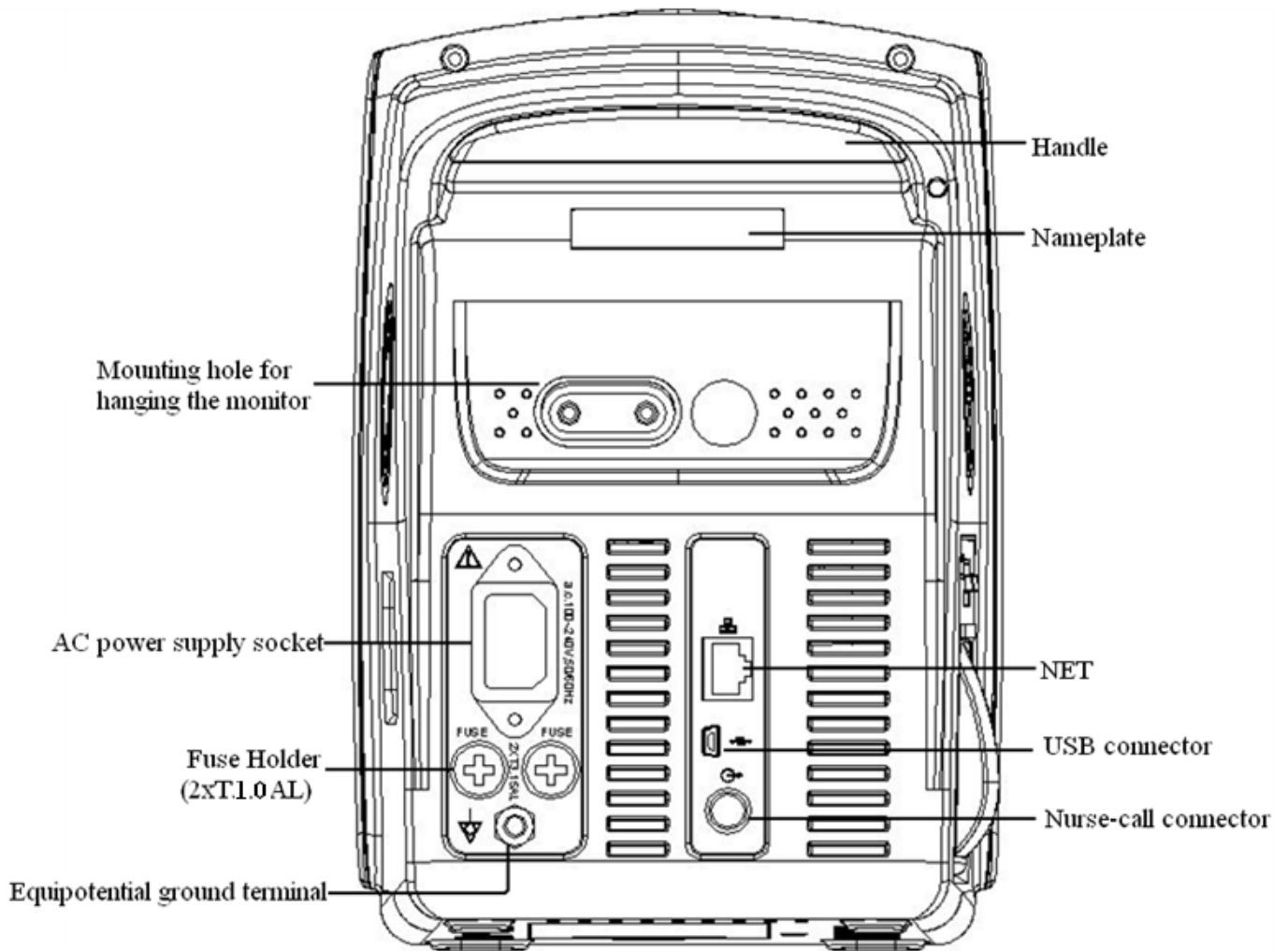

Figure 3.4 Rear Panel

The rear panel of the monitor is as shown in figure 3.4.

Form 3-1 Rear panel Symbols and descriptions

| Symbol | Description                    | Symbol        | Description            |
|--------|--------------------------------|---------------|------------------------|
|        | Warning-- Refer to User Manual | FUSE 2XT1.0AL | Fuse holder            |
|        | USB connector                  |               | Equipotential terminal |
|        | NET                            |               | Nurse-call connector   |

Fuse specification: T1.0AL/250V  $\phi$  5\*20mm



---

### 3.1.4 Underside of the Monitor

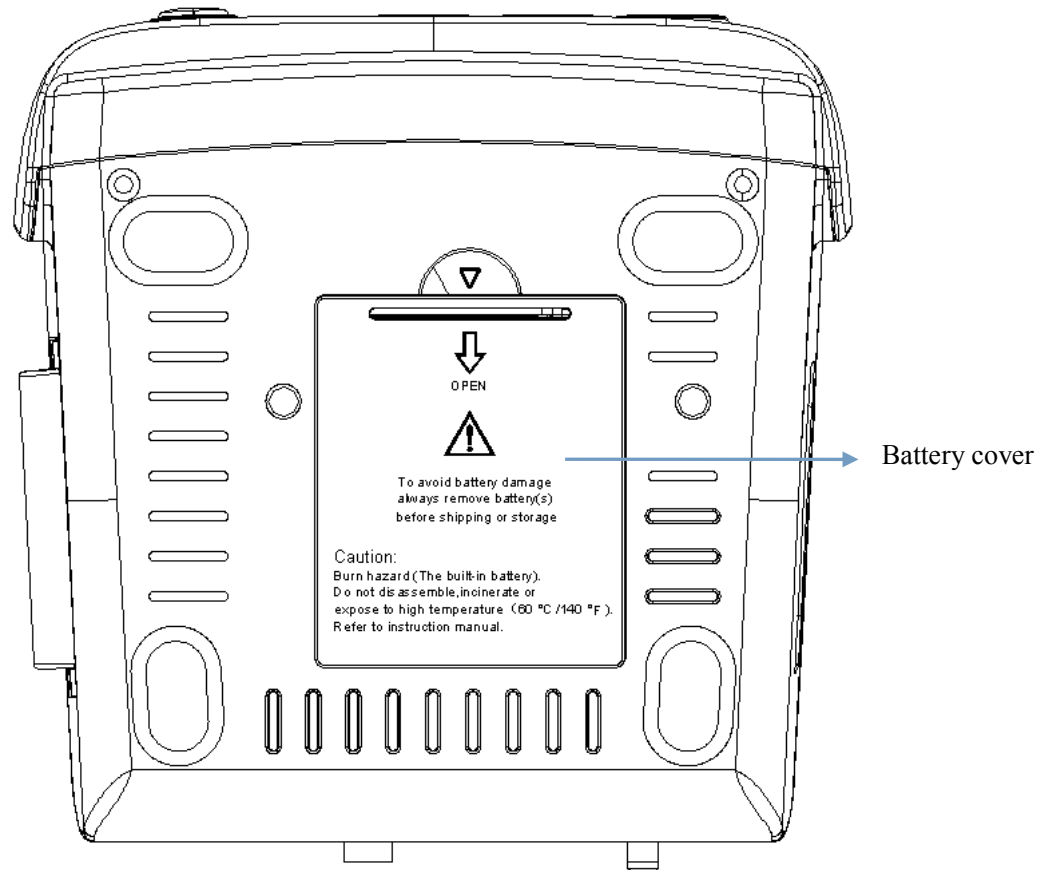
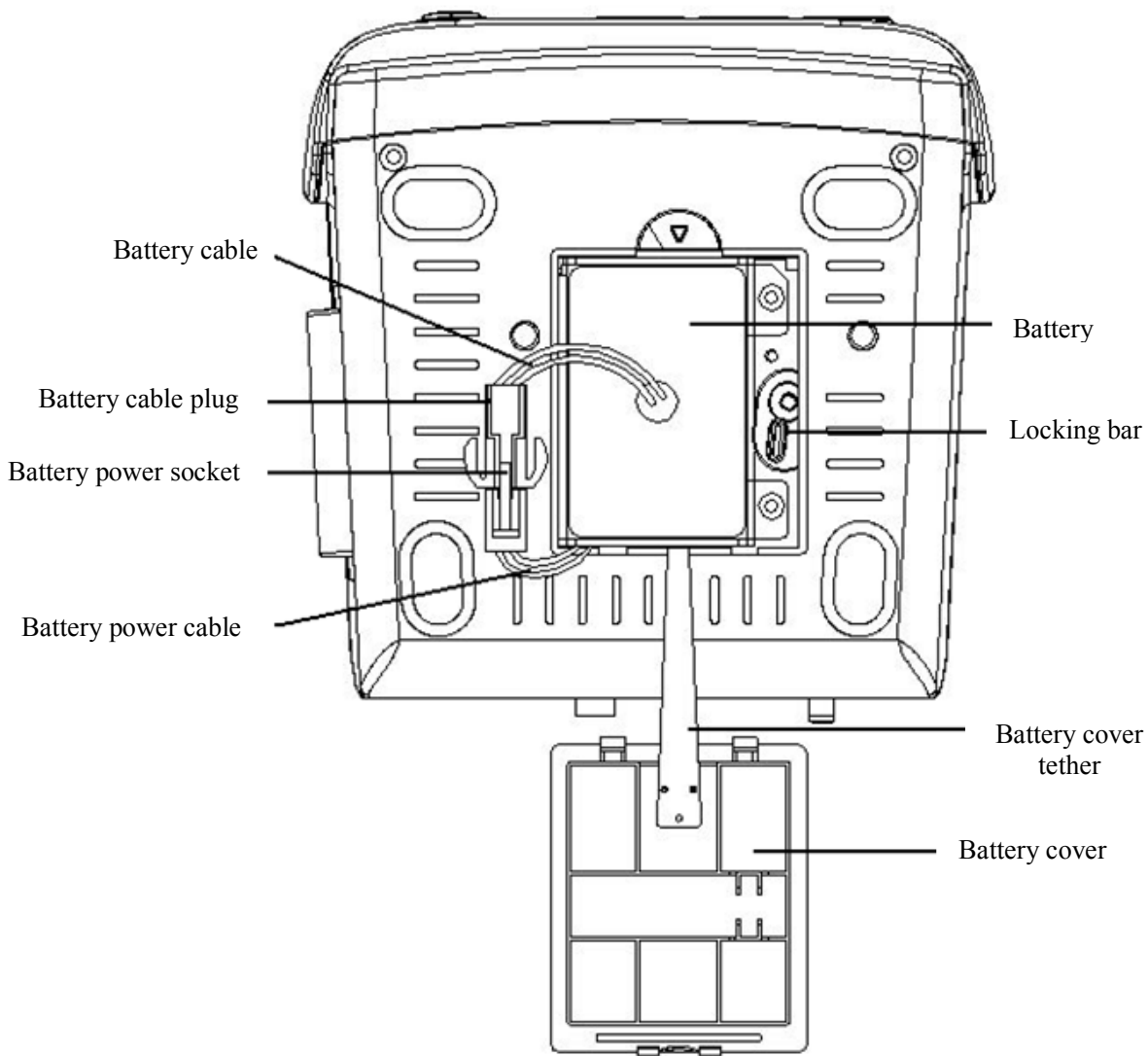

Figure 3.5 Underside of the monitor

### 3.2 Battery Installation

1. Ensure that the monitor is not connected to AC power supply and is turned off.
2. Open the battery cover and move the locking bar aside.
3. Put the battery into the box and move the locking bar back. Please note that the battery cables should be outward.
4. Connect the battery cable plug to the battery power socket in right direction, as shown in figure 3.6.
5. Arrange the wires and close the battery cover.



**Figure 3.6 Battery Installation**



**Warning:**

1. To avoid battery damage always remove battery(s) before shipping or storage.
2. It is recommended to use the battery specified by the manufacturer.
3. The battery service life depends on how frequently and for how long it is used. For a properly maintained and stored lead-acid or lithium battery, its service life is about 2 or 3 years respectively. For more often used models, service life can be less. We recommend replacing lead-acid battery every 2 years and lithium battery every 3 years.

**Caution:**

1. Keep the battery out of the reach of children.
2. Do not disassemble battery.
3. Do not dispose of in fire.
4. Do not cause them to short circuit.

---

## 3.3 Installation

### 3.3.1 Opening the Package and Check

1. Open the package, take out the monitor and accessories from the box carefully and place them on a safe sand table and surface.
2. Open the accompanying document to sort the accessories according to the packing list.

- ◆ Inspect the monitor for any mechanical damages
- ◆ Check all the accessories for any scratch or deformity, especially on connectors, wire and probe parts

☞ You can customize the module configuration by choosing necessary modules to meet your own needs. Therefore, your monitor may not have all the monitoring functions and accessories.

If in doubt, please contact the local dealer or our company in case of any problems. We are to offer you the best solution for your satisfaction.

### 3.3.2 Connecting the Power Supply

#### 1. When powered by AC mains power supply:

- ◆ Make sure that the AC power supply is 100-240VAC, 50/60Hz.
- ◆ Use the power cable prepared by the manufacturer. Insert one end of it to the power port of the monitor and the other end to the grounded three-phase power jack.
- ◆ To eliminate potential differences, the monitor has a separate connection to the equipotential grounding system. Connect one end of the provided ground cable to equipotential grounding port on the rear of the monitor, and connect the other end to one point of the equipotential grounding system.

**Caution: ensure that the monitor is grounded correctly.**

- 🔔 If the mains power is interrupted and restored after 30 seconds (with the mains power switch still on) the monitor will retain the last settings when the monitor restarts.

#### 2. When powered by built-in battery

- ◆Caution: Recharge the battery while it is almost exhausted wherever possible, the charging time should be 13~15 hours long.
- ◆The built-in battery of the monitor must be recharged after transportation or storage. So if the monitor is switched on without being connected to the AC power supply, it may not work properly due to insufficient battery capacity.

### 3.3.3 Starting the Monitor

When the monitor is switched on, the system performs a self-test and then enters the initial display. The orange alarm indicator blinks to inform that the user can begin operating it.

- ◆ Check all the applicable functions to make sure that the monitor works normally.
- ◆ If the battery is used please recharge it after using the monitor to ensure sufficient power storage. It will take minimal 8 hours to charge battery from depletion to 90% charge.

- 🔔 Do not use the device to monitor the patient if there are indications of damage or error message. In this event, please contact the local dealer or our company.

- 🔔 Wait one minute before restarting the monitor after turning it off.

## 3.4 Sensor Placement and Connection

### 3.4.1 ECG Cable Connection

ECG measurement is to collect the ECG signal via the ECG electrodes. Electrode connects the patient and the lead. The lead connects the monitor. The locations of the electrodes are very important for obtaining accurate ECG signals.

1. Connect the cable to the right-panel connector marked with the ECG icon.

2. Select electrodes to be used. Use only one type of electrode on the same patient to avoid variations in electrical resistance. For ECG monitoring, it is strongly recommended to use silver/silver chloride electrodes. When dissimilar metals are used for different electrodes, the electrodes may be subject to large offset potentials due to polarization. Using dissimilar metals may also increase recovery time after defibrillation.

3. Prepare the electrode sites according to the electrode manufacturer's instructions.

4. Skin clean

- Clean and dry-abrade skin to ensure low sensor impedance. Mild soap and Water is recommended as a skin cleanser.

Note: Alcohol is not recommended as a skin cleanser; it leaves a film layer that may cause high sensor impedance. If alcohol is used, ensure 30-second dry time.

- Dry-abrading the skin gently with a dry wash cloth, gauze, or skin preparation product is helpful to remove the non-conductive skin layer.



The symbol indicates that the cable accessories are designed to have special protection against electric shocks, and is defibrillator proof.

The locations of the electrode are in the following Figure:

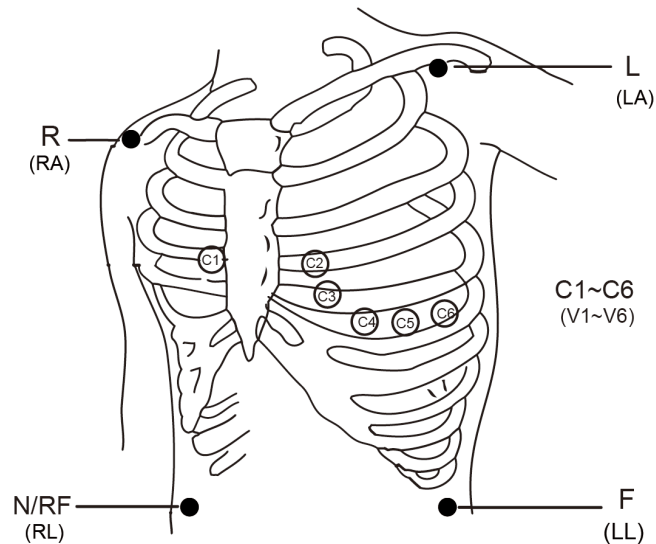

Note: If skin rash or other unusual symptoms develop, remove electrodes from patient.

5. After starting the monitor, if the electrodes become loose or disconnected during monitoring, the system will display "LEAD OFF" on the screen to alarm the operator.

**It might not display ECG waveform when using 3 lead wires but with the setting of 5 lead wires. The 5 lead wires should be used to get full ECG waveform simultaneously.**

6 The ECG leads and their corresponding locations are as follows:

| Lead connection 1<br>(IEC standard) |                 | Lead connection 2<br>(AHA standard) |                 | Electrode placement  |
|-------------------------------------|-----------------|-------------------------------------|-----------------|--|
| Color                               | Electrode label | Color                               | Electrode label |  |
| Red                                 | R               | White                               | RA              | Place on the right arm, or the intersection between the centerline of the right clavicle and Rib 2 |
| Yellow                              | L               | Black                               | LA              | Place on the left arm, or the intersection between the centerline of the left clavicle and Rib 2   |
| Green                               | F               | Red                                 | LL              | Place on the left leg, or left part of the upper abdomen   |
| Black                               | N or RF         | Green                               | RL              | Place on the right leg, or right part of the upper abdomen   |
| White                               | C               | Brown                               | V               | An individual and movable electrode pasted on the chest  |
| White or Red                        | C1              | Brown                               | V1              | On the 4 <sup>th</sup> intercostal space at right border of sternum                                |
| White or Yellow                     | C2              | Brown or Yellow                     | V2              | On the 4 <sup>th</sup> intercostal space at left border of sternum                                 |
| White or Green                      | C3              | Brown or green                      | V3              | The middle line between V2 and V4  |
| White or brown (Blue)               | C4              | Brown or blue                       | V4              | The intersection between the centerline of the clavicle and the 5 <sup>th</sup> intercostal        |
| White or Black                      | C5              | Brown or Red                        | V5              | The intersection between the left anterior axillary line and the horizontal level of V4            |
| White or Purple                     | C6              | Brown or purple                     | V6              | The intersection between the left mid-axillary line and the horizontal level of V4                 |

**Table 3-2**

### **Safety Instructions for ECG Monitoring**

- ☛ Use the same type electrode on a patient. If skin rash or other unusual symptom occurs, remove electrodes from patient. Do not attach electrodes on the patient with an inflammation of the skin or scores on skin.
- 🔔 Gima Vital Pro Monitor can only be equipped with ECG leads provided by our company; using ECG leads supplied by other companies may cause improper performance or poor protection while using defibrillator.
- 🔔 Electric parts of electrodes, leads and cable are forbidden to contact any other conductive parts (including ground).
- 🔔 Gima Vital Pro Monitor can resist against defibrillator and electro-surgical unit. Readings may be inaccurate for a short time after or during using defibrillator or electro-surgical unit.
- 🔔 Transient caused by cable circuitry blocks while monitoring may be similar to the real heartbeat waveform, as a result resistance heart rate alarm rings. If you put the electrodes and cable in proper places according to this manual's instructions and the instructions for using electrode, the chance of this transient occurring will be decreased.
- ☛ Besides the improper connection with electro-surgical unit may cause burns, the monitor may be damaged or arouse deviations of measurement. You can take some steps to avoid this situation, such as do NOT use small

---

ECG electrodes, choosing the position which is far away from the estimated Hertzian waves route, using larger electro-surgical return electrodes and connecting with the patient properly.

- 🔔 ECG leads may be damaged while using defibrillator. If the leads are used again, please do the functional check first.
- 🔔 When removing the ECG cable, hold the head of the connector and pull it out.
- 🔔 When the monitor is inoperable due to an overload or saturation of any part of the amplifier, it will prompt “Lead off” to remind operator.
- 🔔 No predictable hazard will be caused by the summation of leakage currents when several item of monitor are interconnected.
- 🔔 Cardiac pacemaker pulse inhibition function is available while calculating heart rate, this function is always effective on all filter settings for ECG monitoring and it can not be disabled by user.

### 3.4.2 Blood Pressure Cuff Connection

1. Connect the cable to the right-panel connector marked with the NIBP icon.
2. Select the appropriate cuff (see below) and wrap around the patient’s upper arm.

#### Cuff requirements:

- 1) An appropriate cuff should be selected according to the size of the subject. The cuff width should be 2/3 of the length of the upper arm. The cuff inflation part should be long enough to permit wrapping 50-80% of the limb concerned.

**Note: The size of the cuff selected should suit the patient while measuring.**

- 🔔 When putting on the cuff, wrap it around the upper arm evenly to appropriate tightness.
- 2) Remember to empty any residual air in the cuff before the measurement commences.
  - 3) Locate the cuff in such a way that the “φ” mark is at a location where the clearest pulsation of brachial artery is observed.
  - 4) The cuff should be tightened to a degree where insertion of one finger is possible.
  - 5) The lower end of the cuff should be 2cm above the elbow joint.
3. Patient position while taking the blood pressure measurement for correct result:
    - Comfortably seated
    - Leg uncrossed
    - Feet flat on the floor
    - Back and arm supported
    - Middle of the Cuff at the level of the right atrium of the heart

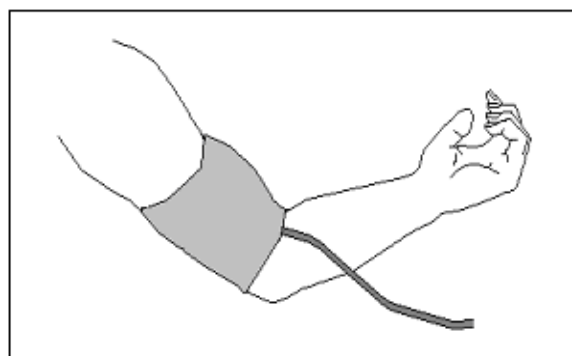
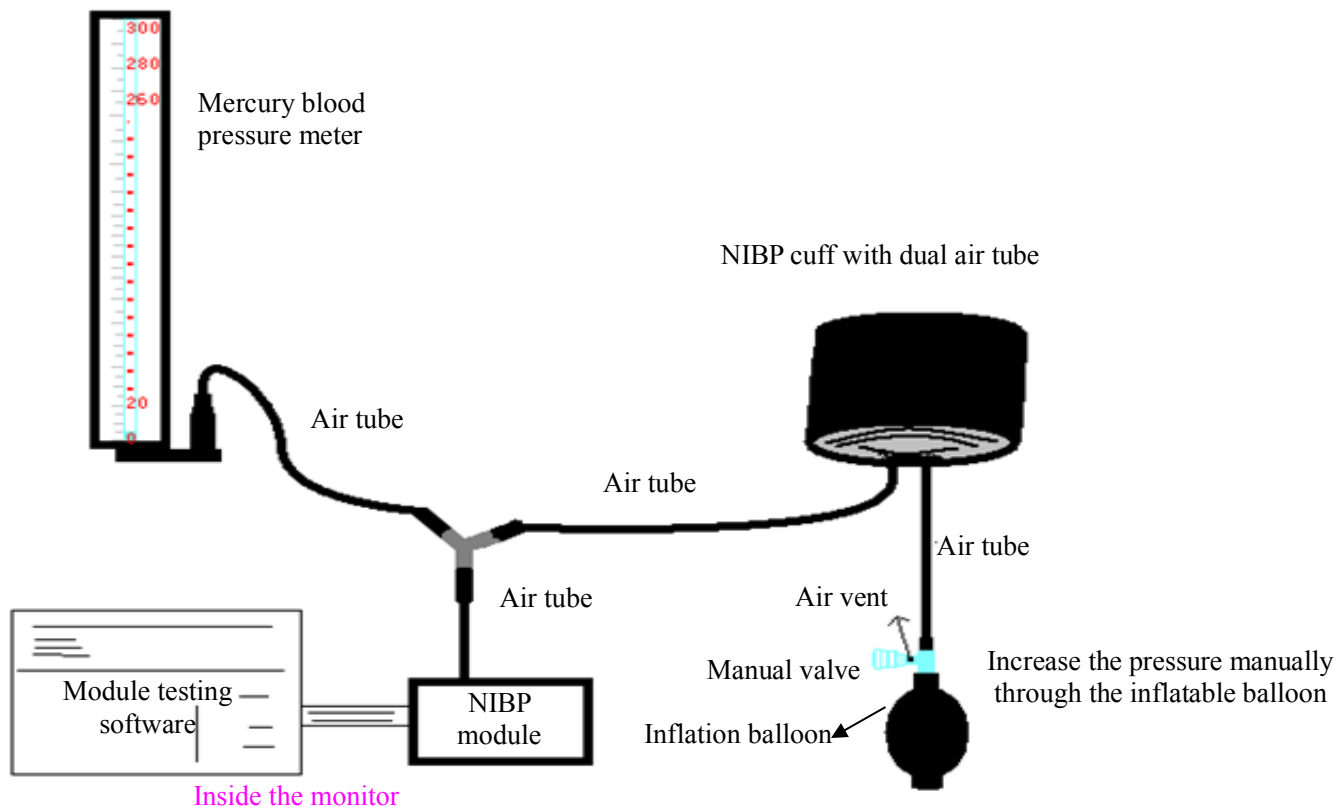

**Figure 3.7 Cuff Placement**

➤ **Pressure Accuracy Verification**

Pressure Accuracy Verification is a function to inspect the accuracy of pressure measurement by the NIBP module inside the device. Technician or equipment manager should do pressure accuracy verification every half year or year in order to check if the pressure measurement still conforms to the requirement of product performance. If the deviation is beyond the declared specification, it is permitted to return it to factory for repair or calibration.

Before verification, please connect the monitor to a precise pressure meter such as a mercury pressure meter, which is used as the reference meter.



**Figure 3.8 Connection of Pressure calibration fixture**

**Mode 1: Automatic inflation**

The inflation can be activated by Monitor so the pressure will increase automatically until it exceeds the limit value specified in table A. This pressure limit value depends on the patient type selection as shown in table A:

|           |         |
|-----------|---------|
| Adult     | 240mmHg |
| Pediatric | 200mmHg |
| Neonate   | 120mmHg |

Table A

During inflation, the Monitor will close the deflation valve, and pressure reading will be shown as inflation takes place. If there is no manual deflation operation, the pressure will persist until deflation by the manual valve. It is necessary to deflate in several steps to verify the pressure accuracy at points across the full scale measurement range.

**Mode 2: Manual inflation.**

Increase the pressure manually by the inflation balloon, and the verification can be done by applying different pressures manually. If the increased pressure exceeds the given limit as shown in table B, the Monitor will deflate automatically because of the over-pressure protection valve in each mode.

|           |         |
|-----------|---------|
| Adult     | 300mmHg |
| Pediatric | 240mmHg |
| Neonate   | 140mmHg |

Table B

- 
- 🔔 **After verification, press the button again to return to normal working mode and continue operation, or the NIBP key will be invalid.**
  - 🔔 **Pressure accuracy verification should be undertaken by a technician or equipment manager and never with the BP cuff still on a patient.**

➤ **Air Leakage Check**

In order to avoid measurement errors or even no measurement result caused by air leakage in the pneumatic system including the cuff during measuring, it is recommended to check if there is leak in the pneumatic system as well.

- 🔔 **Please remove the cuff from patient while performing the leakage check.**

**Safety Instructions for NIBP Monitoring**

- 🔔 When taking the NIBP measurement of a pediatric or neonate's (less than 10 years old), do NOT operate in the adult mode as the high inflation pressure may cause lesion or even body putrescence.
- 🔔 It is recommended to take the blood pressure measurement manually. Automatic measurement should be used at the presence of a doctor/nurse.
- 🔔 NIBP monitoring is prohibited to those who have severe hemorrhagic tendency or with sickle cell disease, or partial bleeding will appear.
- 🔔 Manual blood pressure measurement is recommended or the automatic measurement used in the presence of a clinician.
- 🔔 Confirm your patient category (adult, pediatric or neonate) before measurement.
- 🔔 Do NOT use the NIBP cuff on limbs with transfusion tubes, intubation or skin lesions, otherwise, damages may be caused.
- 🔔 If automatic blood pressure measurement is set for too long, the limb connected to the cuff may possibly experience purpura, lack of blood and neuralgia. In order to protect patient, it is requested to inspect the luster, the warmth and sensitivity of the body extremity frequently. On observation of any abnormality, immediately stop the blood pressure measurement.
- 🔔 The patient should relax as much as possible during the measurement.
- 🔔 It's recommended that the 5min should elapse before starting the first measurement.
- 🔔 The patient should lie in bed or sit in a chair, in order for the cuff and the heart to be at the same level and the most accurate measurement to be taken. Other postures may lead to inaccurate measurement.
- 🔔 Do not speak or move before or during the measurement. Ensure that the cuff will not be hit or touched by other objects.
- 🔔 The measurements should be taken at appropriate intervals. Continuous measurement at too frequent intervals may lead to compression of the arm, reduced blood flow and lower blood pressure, and result in inaccurate measurement of blood pressure. Two minutes measurement intervals are recommended.
- 🔔 When an adult is monitored, the machine may fail in giving the blood pressure measure if the pediatric mode is selected.
- 🔔 Prior to use of the cuff, empty the cuff until there is no residual air inside it to ensure accurate measurement.
- 🔔 Do NOT twist the cuff tube or put heavy things on it.
- 🔔 When unplugging the cuff, hold the head of the connector and pull it out.
- 🔔 When the monitor is used with electro-surgical unit, do not allow the cuff, bladder and air tube contact any part of the electro-surgical unit to prevent the patient from hurt caused by burning.
- 🔔 Make sure that the device is used in the environment specified on this User Manual, or inaccuracy result may be caused.





The symbol indicates that the cable and accessories are designed to have special protection against electric shocks, and is defibrillator proof.

### 3.4.3 SpO<sub>2</sub> Sensor Connection

The SpO<sub>2</sub> sensor is very delicate. Please follow the steps and procedures below when using it as failure to do so correctly can cause damage to the SpO<sub>2</sub> sensor.

**Operation procedure:**

1. Connect the SpO<sub>2</sub> sensor to the connector labeled “SpO<sub>2</sub>”. **When unplugging the probe, be sure to hold the head of the connector and pull it out.**
2. If the finger clip SpO<sub>2</sub> sensor is used, insert one finger into the sensor (index finger, middle finger or ring finger with short nail length) as shown in the figure below.

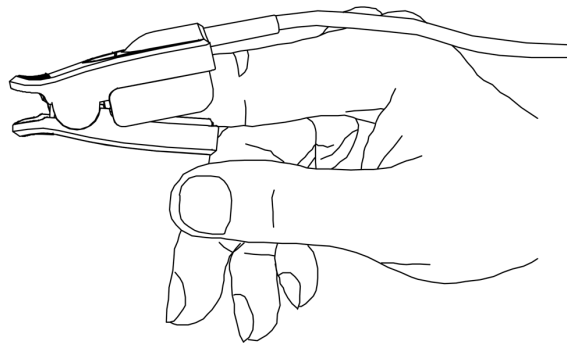
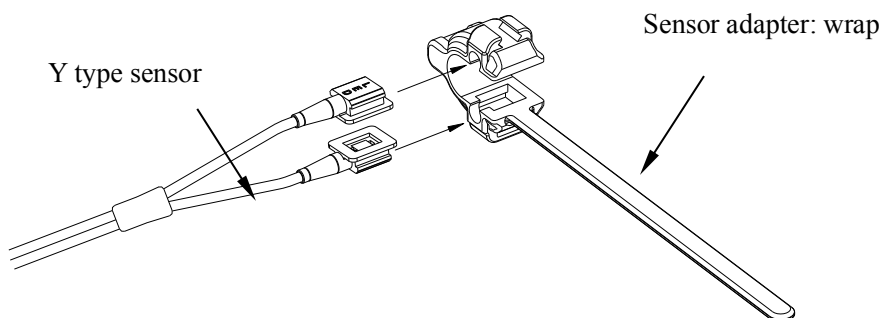

**Figure 3.9 Finger clip SpO<sub>2</sub> sensor placement**

When selecting a sensor, consider the patient’s category, adequacy of perfusion, availability of probe site and anticipated monitoring duration. Use only SpO<sub>2</sub> probes provided by our company with this monitor. Read the following table for SpO<sub>2</sub> probe information. Refer to Chapter 11.5 for the detailed instructions of each SpO<sub>2</sub> probe.

| SpO <sub>2</sub> Probe                          | Patient Category |
|---|------------------|
| SpO <sub>2</sub> Finger Clip Sensor (reusable)  | Pediatric        |
| SpO <sub>2</sub> Finger Rubber Sensor(reusable) | Adult            |
| SpO <sub>2</sub> Finger Clip Sensor(reusable)   | Adult            |

3. If the neonate SpO<sub>2</sub> sensor is used, please follow Figure 3.10 to connect.



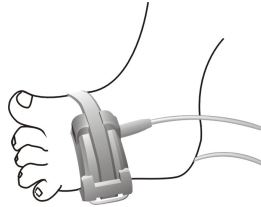

**Figure 3.10 Neonate SpO<sub>2</sub> sensor placement**

High ambient light sources such as surgical lights (especially those with a xenon light source), bilirubin lamps, fluorescent lights, infrared heating lamps, and direct sunlight can interfere with the performance of a SpO<sub>2</sub> sensor. To prevent interference from ambient light, ensure that the sensor is properly applied, and cover the sensor site with opaque material.

Failure to take this action in high ambient light conditions may result in inaccurate measurements.

If patient movement presents a problem, verify that the sensor is properly and securely applied; move the sensor to a less active site; use an adhesive sensor that tolerates some patient motion; or use a new sensor with fresh adhesive backing.

For reusable sensors, follow the sensor directions for use for cleaning and reuse. For single-patient use sensors, use a new sensor for each patient. Do not sterilize any sensor by irradiation, steam, or ethylene oxide.

#### **Safety Information for SpO<sub>2</sub> Monitoring**

- Continuous use of the SpO<sub>2</sub> sensor may result in discomfort or pain, especially for those with microcirculatory problem. It is recommended that the sensor should NOT be applied to the same place for over two hours, change the measuring site periodically if necessary.
- The SpO<sub>2</sub> measuring site must be examined carefully for certain patient groups. Do NOT place the SpO<sub>2</sub> sensor on the finger of a patient with edema or fragile tissue.
- 🔔 If sterile packaging of a disposable SpO<sub>2</sub> sensor is damaged, do not use it.
- 🔔 Check the SpO<sub>2</sub> sensor and cable before use. Do NOT use a damaged SpO<sub>2</sub> sensor.
- 🔔 If the temperature of SpO<sub>2</sub> sensor is abnormal, do not use it any more.
  - Please do not allow the cable to be twisted or bent.
  - Do NOT put the SpO<sub>2</sub> sensor and pressure cuff on the same limb, otherwise the NIBP measuring will affect SpO<sub>2</sub> measuring and cause an alarm error.
  - Using nail polish or other cosmetic product on the nail may affect the accuracy of measurement.
  - The fingernail should be of normal length.
  - The SpO<sub>2</sub> sensor cannot be immersed in water, alcohol or cleanser completely, because the sensor has no capability to resist the harmful ingress of water

#### **3.4.4 TEMP Transducer Connection**

**Please follow the corresponding methods to make temperature measurement according to the temperature transducer you selected.**

##### **◆ Connecting methods for thermal temperature transducer:**

1. Securely attach the transducer to the patient;
2. Connect the cable to TEMP probe connector in the front panel.

##### **◆ Connecting methods for infrared temperature probe:**

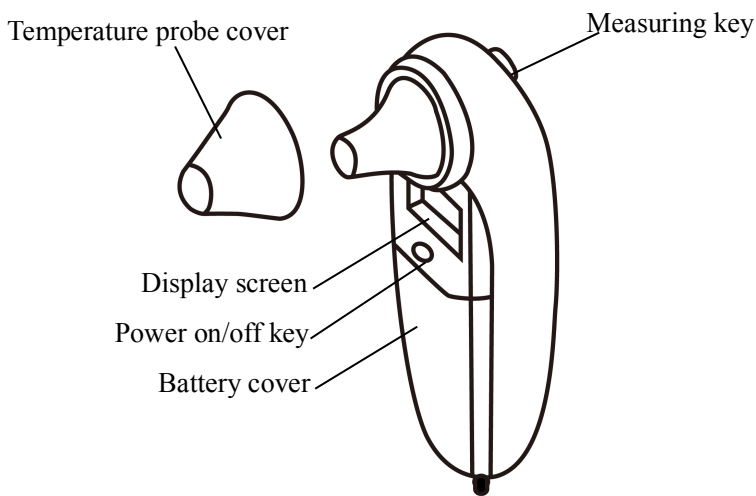

Figure 3.11A the infrared temperature probe

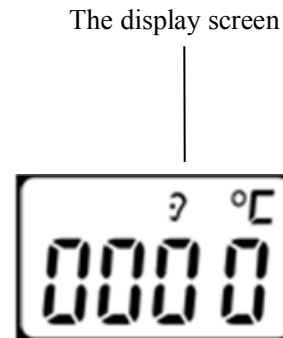

Figure 3.11 B

1. Connect the infrared temperature probe to the connector on the front side of device marked "TEMP".
2. When the probe screen shows as figure 3.11B and the temperature unit "°C" is blinking, the user can begin to take the measurement.
3. Insert the tip of the temperature probe into the earhole and press the measuring key to start the measurement. A short beep means the measurement has finished and the result will be displayed on the both probe and the monitor screen .

Note: When unplugging the probe, be sure to hold the head of the connector and pull it out.

### 3.4.5 Loading printer paper (if printer is installed)

#### Operation procedures for loading printer paper:

1. To open the printer cover, press two thumbs firmly on both "OPEN" notches.
2. Move the tab of the left rubber roller lock 90° upwards to unlock it, refer to the following figure with mark ①.
3. Cut one end of the paper into a triangle, and load the paper from the underside of the rubber roller.
4. Turn the roller clockwise to roll the paper rolled, and put the paper roll into the compartment.
5. Pull the paper out of the paper slot on the shield.
6. Move the tab of the rubber roller lock 90° downwards to lock it.
7. Put the shield back in position and secure it.

#### Operation procedures for taking out printer paper roll:

Steps 1~2: Same as above.

Steps 3. Roll the loading roller anti-clockwise and pull the paper out.

Steps 4~5: As steps 6~7 above.

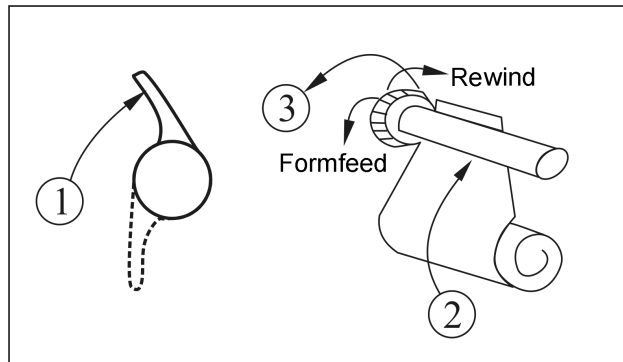

**Figure 3.12 Loading and taking out printer paper**

**P8 printer may be used due to the different configuration**

**P8 printer operation instruction:**

Power indicator: green light shows the power is on, when the monitor is out of power, the green light is off.

Error indicator: red light which shows the printer is out of paper or the printer paper is not properly installed. When the printer successfully installs, the red light is off.

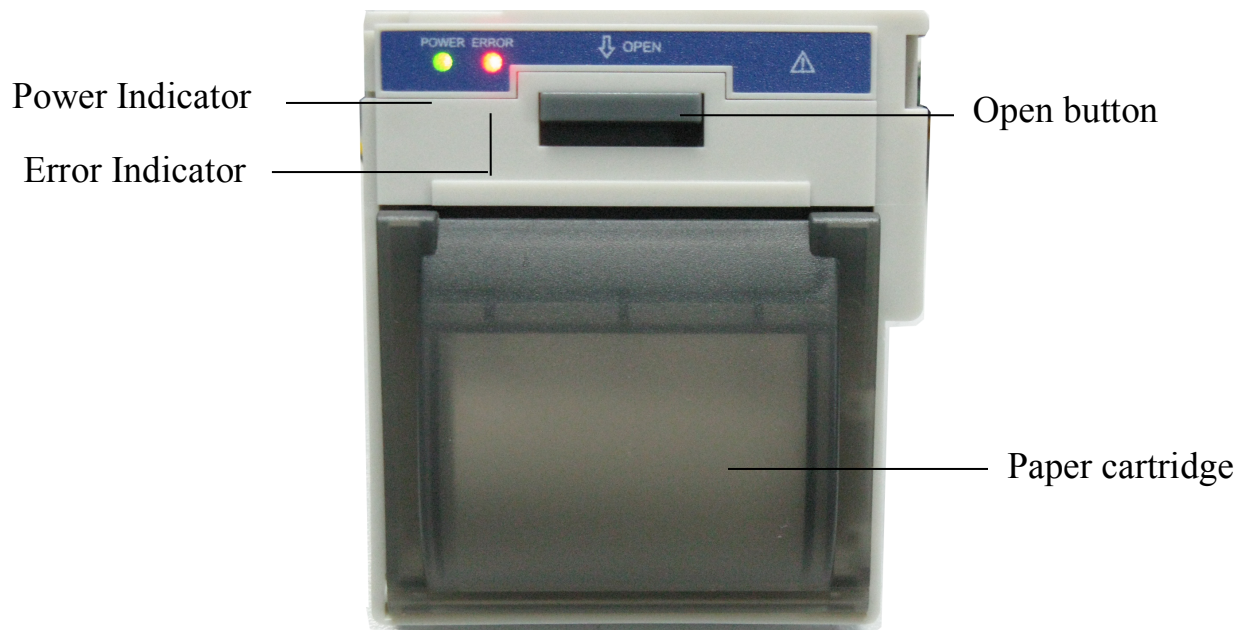

**Figure 3.12 P8 printer**

---

**Loading printer paper:**

Step 1: press and hold down the cartridge button to open the paper cartridge;

Step 2: Install the paper to the printer properly, pull the paper out of the printer for 2 cm, as shown in figure 3.13.

Step 3: Close the printer cover along the direction of arrow, as shown in figure 3.13.



**Figure 3.13 printer paper**

# Chapter 4 Operations

This chapter introduces the display screen and operating instructions, including the initial screen, default screen, system menu, menu setup and data upload. Before operating the monitor, please refer to the related section for connecting the accessories.

Note: The monitor you purchased may not cover all the mentioned functions according to its configuration.

## 4.1 Initial Monitoring Screen

To switch on the monitor, press and hold the "⏻" power key. When you hear a "beep", the LCD will display as shown in figure 4.1, which means that the monitor has started successfully.



Figure 4.1 Startup screen

A short press of the power key "⏻" will switch between power saving modes and full power mode. Power saving modes mean the LED and LCD display become darker, the brightness has two levels.

A long press of the power key "⏻" will give a black screen as the displays turn off and means that the monitor has shut down successfully.

## 4.2 Default Screen

When the monitor is powered on, the default display screen is as shown in figure 4.2.

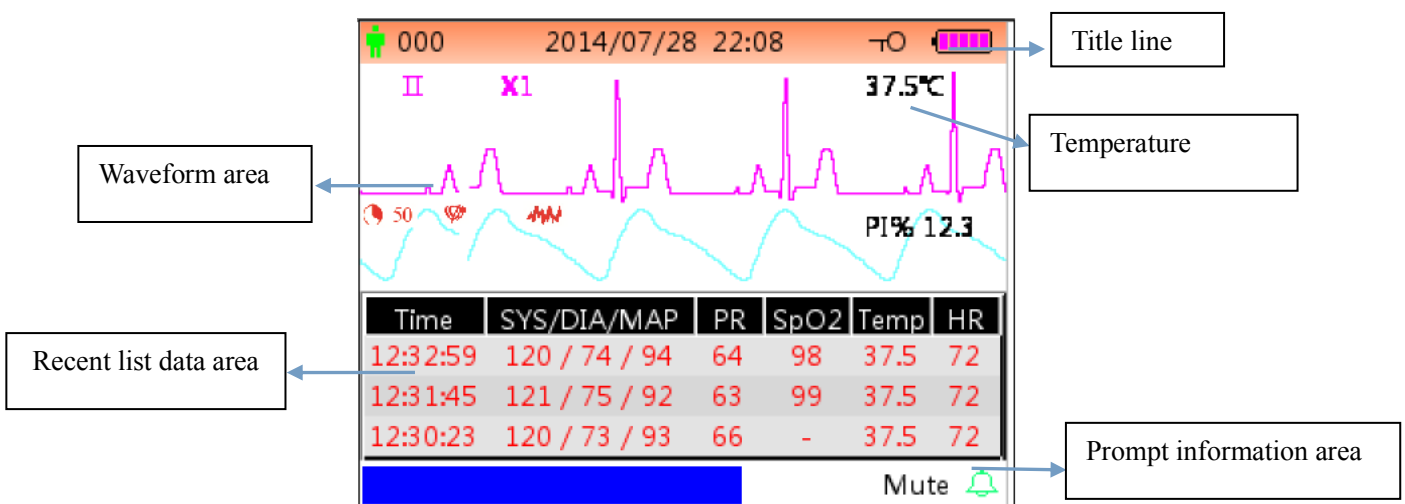

Figure 4.2A Default monitoring screen (monitor with ECG function)

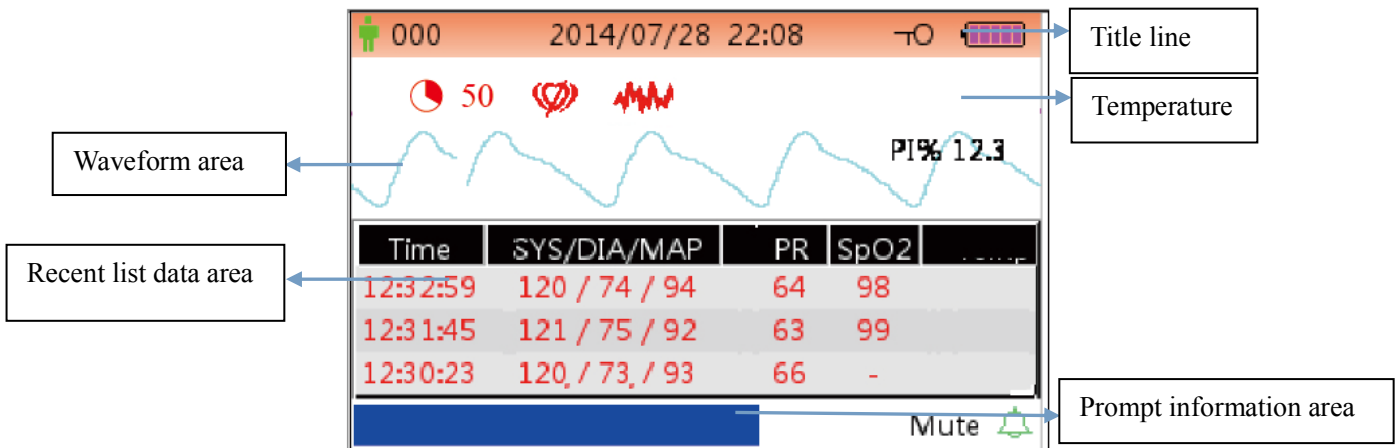

Figure 4.2B Default monitoring screen (monitor with SpO<sub>2</sub> and NIBP function only)



Figure 4.2C Default monitoring screen (monitor with SpO<sub>2</sub> function only)

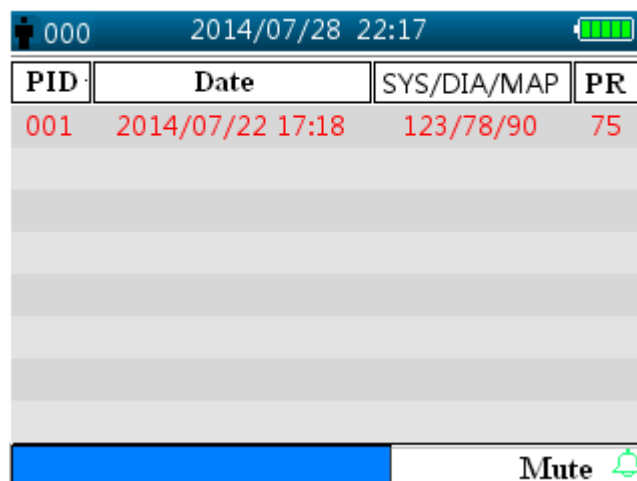





Figure 4.2D Default monitoring screen (monitor with NIBP function only)

Note: if the monitor is configured with NIBP function only, then the monitoring screen shows NIBP list and event list only.

Title line:

- ✧ "000": the ID number of the patient currently being monitored.
- ✧ "2014/07/28 22:08": the current date and time, year/month/day hour:minute.

- ◇ : key-lock icon, when this icon appears, it means that the key operation is disabled.  
Note: the key-lock status can be set at any screen view by combining the given keys. During key-lock status, all key operations are disabled except Power button and combination keys for unlocking operation.
- ◇ : net connection icon, indicates that the device is connected to the network. If the device is disconnected from the network, then the icon will disappear.
- ◇ : battery voltage indicator.
- ◇ “PLETH”: indicating the displayed waveform is plethysmogram.





### Waveform area:

- ◇ "II": ECG lead.
- ◇ "x1": ECG waveform gain.
- ◇ “PI% 12.3”: the label and value of perfusion index. This item is displayed only when “Setup Menu→SpO<sub>2</sub>→PI Display” is set as “ON”.

Note: PI function is optional, please refer to the monitor in your hand, we will not cover it again.

- ◇ "37.5°C"/"-- °C": the measured temperature value. This function is optional.

### SpO<sub>2</sub>:

- ◇ “ 50” (When Nellcor SpO<sub>2</sub> is configured AND setting SatSeconds value is not zero): The icon of SatSeconds. Here “50” is the SatSeconds setting value. “” is the circle icon filling. When the circle is fully filled, an alarm will be triggered. The monitor shall display SatSeconds icon when it is activated via SpO<sub>2</sub> setting menu. More information, please see 4.9.2 SpO<sub>2</sub> Setup.
- ◇ “” (Appears only when Nellcor SpO<sub>2</sub> is configured): Pulse Search Icon. After SpO<sub>2</sub> sensor is applied on the measuring site, if the monitor detects pulse beat, the Pulse Search Icon will appear until the first valid reading of SpO<sub>2</sub> is available. The Pulse Search Icon will appear continuously under the condition of loss-of-pulse.
- ◇ “” (Appears only when Nellcor SpO<sub>2</sub> is configured): Interference Icon. The Interference Icon will appear continuously during periods of strong motion artifact interference.

If the accessories are connected incorrectly or disconnected from the monitor, the message "Probe off" and (or) "ECG lead off" will appear on the screen.

### NIBP list area:

When blood pressure measurement is taken, the data display area displays the recent 4 groups of data, the form is as shown in figure 4.2.





- ◇ "Time": the measuring time.
- ◇ "SYS/DIA/MAP": systolic/diastolic/arterial mean pressure.
- ◇ "PR": the measured pulse rate from the blood pressure measuring channel or the pulse rate value from oximetry measuring channel. The PR value from oximetry will take priority in the display.
- ◇ "SpO<sub>2</sub>": oxygen saturation (SpO<sub>2</sub> for short).
- ◇ "TEMP": the temperature value. This function is optional.
- ◇ "HR": the heart rate.

Note: 1. If the device is re-started, the data in the list data area will be cleared.  
2. Invalid values will be displayed as "--"







### Prompt Info. area:

- ◇ "MAP over-limit": displays a message for current alarm event indicating that the measured MAP value exceeds the preset value.







- ◇ "Mute 112 ": display the status of the alarm silence, and the counting down the time that the alarm sound is silenced for.  shows that the alarm sound is enabled;  shows that the alarm sound is silent temporarily for 120 seconds;  shows that the alarm sound is disabled.

**Operation instruction:**

- Short pressing the display view "" key to shift screen views.
- Long press the display view "" key to enter into Menu setup screen.
- For monitor without ECG function, hold Auxiliary key "" firstly, then press NIBP setup key "", by doing this it can lock / unlock key operation. For monitor with ECG function, hold ECG lead key "" firstly, then press NIBP setup key "", by doing this it can lock / unlock key operation.  
Note: This function is available in any screen view, we will not cover it again in the following.
- Short press the print key "" to activate printing with the format specified by "Setup Menu→System→Print" if the printer is installed.

**The following operation is also for the monitor with ECG function.**

- Pressing OK "" key to freeze / unfreeze ECG waveform.
  - Short pressing Lead "" key to shift the ECG lead.
  - Short pressing Up/Down (" " / " ") key to change ECG waveform gain.
- Note: there are 7 screen views (depending on your configuration): default screen, screen for real-time ECG waveform only, NIBP list screen, SpO<sub>2</sub> data list screen, alarm event list screen, screen for graphic trend and ECG waveform recall. The following sections will describe each one of these 7 screens.

### 4.3 Screen for Real-time ECG waveform Only (Optional)

Note: this screen is only for the monitor with ECG function.

Real-time ECG waveform screen is as shown in figure 4.3.







Figure 4.3 Real-time ECG waveform screen

- ◇ "II": ECG lead.
- ◇ "X2": ECG waveform gain.

**Operating instructions:**

- Pressing OK "" key to freeze / unfreeze ECG waveform.

- Short pressing Lead "  " key to shift the ECG lead.
- Short pressing Up/Down("  " / "  ") key to change ECG waveform gain.
- Short pressing Print "  " key to start / stop printing real-time ECG waveform.

## 4.4 Screen Display for ECG Waveform Recall (Optional)

Note: this screen is only for the monitor with ECG function.

ECG waveform recall screen is as shown in figure 4.4.

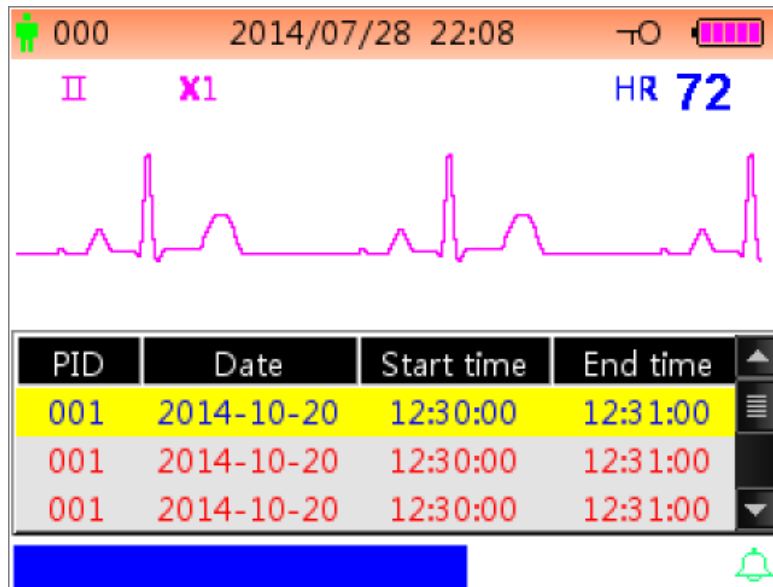

Figure 4.4 ECG waveform recall screen

### ECG waveform displaying area:

- ✧ "II": ECG lead.
- ✧ "X1": waveform gain.
- ✧ "HR 72": heart rate mark and the measured heart rate.

### ECG records list area:

- ✧ "PID": the patient ID number.
- ✧ "Date": the date of ECG measurement record.
- ✧ "Start Time": the start time of ECG measurement record.
- ✧ "End Time": the end time of ECG measurement record.

Note: one single ECG record starts from the valid ECG signal (when message "Lead off" disappears) and finishes when ECG lead is off. One single ECG record is not longer than 1 hour.

### Operating instructions:







- Press Up "  " key or Down "  " key to select one ECG record, then press OK key to recall the selected ECG waveform. Press "  " key or "  " key to scroll the ECG waveform forward / backward.
- Press print "  " key to print the selected ECG waveform record.
- Long pressing OK "  " key, then a dialog of deleting records pops up, as shown in figure 4.5, the user can delete all history ECG waveform data according to prompt.



Figure 4.5 Delete ECG history

## 4.5 NIBP List Screen (Optional)





Note: the screen below is only for the monitor with NIBP function.  
The NIBP List screen is as shown in Figure 4.6.

| PID | Date/Time           | SYS/DIA/MAP | PR |
|-----|---------------------|-------------|----|
| 001 | 2014/12/22 09:21:20 | 78/99/82    | 8  |
| 001 | 2014/12/22 09:21:09 | 78/99/82    | 7  |
| 001 | 2014/12/22 09:20:56 | 78/99/82    | 6  |
| 001 | 2014/12/22 09:20:45 | 78/99/82    | 5  |
| 001 | 2014/12/22 09:20:30 | 78/99/82    | 4  |
| 001 | 2014/12/22 09:15:45 | 78/99/82    | 3  |
| 001 | 2014/12/22 09:15:21 | 78/99/82    | 2  |
| 001 | 2014/12/22 09:15:08 | 78/99/82    | 1  |

Figure 4.6 NIBP List

In this screen, the first column is the patient ID, the second column is NIBP recording time, the third column is NIBP value, and the fourth column is pulse rate (measured by NIBP module).

### Operating instruction:

- Short press the Up " " or Down " " key to turn to previous or next page for view other NIBP records.
- Short press the Print " " key to print the current NIBP list.
- Long press the OK " " key to bring up a dialogue for deleting data records where the user can choose to delete all NIBP data records.

## 4.6 SpO<sub>2</sub> Data List Screen (Optional)

Note: the screen below is only for the monitor with SpO<sub>2</sub> function.

SpO<sub>2</sub> data list screen is as shown in Figure 4.7.

| PID | Date/Time           | SpO2 | PR |
|-----|---------------------|------|----|
| 001 | 2014/12/22 13:34:02 | 98   | 74 |
| 001 | 2014/12/22 13:33:54 | 97   | 71 |
| 001 | 2014/12/22 13:33:54 | 98   | 72 |
| 001 | 2014/04/02 17:04:31 | 97   | 71 |
| 001 | 2014/04/02 17:04:19 | 98   | 71 |

SpO2 over limit Mute 111

**Figure 4.7 SpO<sub>2</sub> data list screen**

In this screen, the first column is the patient ID, the second column is SpO<sub>2</sub> recording time, the third column is SpO<sub>2</sub> value, and the fourth column is pulse rate (measured by SpO<sub>2</sub> module).

**Operating instruction:**

- Short press the Up "▲" or Down "▼" key to scroll to previous or next page for view other SpO<sub>2</sub> records.
- Short press the Print "🖨️" key to print the current SpO<sub>2</sub> list.
  - Long press the OK "⏹️" key to bring up a dialogue for deleting data records, where the user can choose to delete all SpO<sub>2</sub> data records.

## 4.7 Alarm Event List Screen

The Alarm Event List screen is as shown in Figure 4.8.

| Date/Time   | Event            | Value | Hi/Lo |
|-------------|------------------|-------|-------|
| 12/22 09:21 | SYS over limit   | 99    | 90/60 |
| 12/22 09:21 | SYS over limit   | 99    | 90/60 |
| 12/22 09:21 | SYS over limit   | 99    | 90/60 |
| 12/22 09:21 | SYS over limit   | 99    | 90/60 |
| 12/22 09:21 | SYS over limit   | 99    | 90/60 |
| 12/22 09:21 | NIBP signal weak | --    | --    |
| 12/22 09:21 | NIBP signal weak | --    | --    |
| 12/22 09:21 | SYS over limit   | 99    | 90/60 |

Over motion

**Figure 4.8 Alarm event list**

In this screen, the first column is the time that the alarm occurred (format is month-day hour:minute), the second column is the event description, the third column is the onset value, and the fourth column is the high/low limit value.

- Short press the "▲" or "▼" key to scroll to previous/next page for view other alarm events. Note: if the event description is too long to be shown, pressing the OK key can show the full description, but the third and fourth column will not be displayed.
- Short press the print "🖨️" key to print the event list of the current page.

- Long press the "OK" key to bring up a dialogue for deleting data records, where the user can choose to delete all alarm events data.

## 4.8 Trend Graph Display (for SpO<sub>2</sub> Option)

The trend graph display screen is as shown in Figure 4.9.

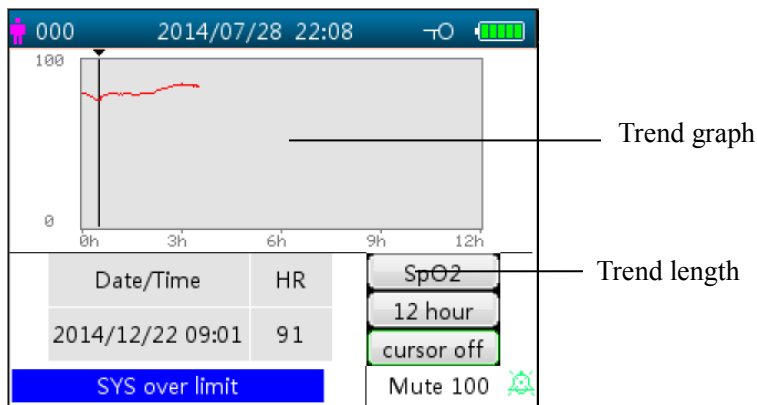

Figure 4.9 Trend Graph screen

### Screen description

- ✧ "**SpO<sub>2</sub>**": **SpO<sub>2</sub> trend graph**. If the monitor has ECG function, then "SpO<sub>2</sub>" and "HR" can be optional.
- ✧ "**12 hours**": **the trend length of SpO<sub>2</sub> trend graph**; there are three options: "12", "24" or "96" hours. Press OK "OK" key to select the trend length from "12 Hour", "24 Hour" and "96 Hour", then the trend graph will display the SpO<sub>2</sub> trend curve for the selected period.
- ✧ "**Cursor on**": enables the display of cursor on the trend graph, i.e. the vertical cursor line will be displayed in the trend graph, so the user can move the cursor by pressing the up/forward "Up" and down/backward "Down" keys to inspect the SpO<sub>2</sub> value at the given time.
- ✧ "**SpO<sub>2</sub>**": indicates that the trend graph is for SpO<sub>2</sub>, and the value below it shows the SpO<sub>2</sub> value at the cursor position.  
It can be "PR" or "HR" (for monitor with ECG function) by selection.
- ✧ "Date/Time": the starting time of the trend graph.

### Instructions for viewing the trend graph:

- Select "cursor on" and press the OK "OK" key to confirm, and "cursor on" switches to "cursor off". You can then press the up "Up" or down "Down" key to move the vertical cursor and the list box below will display SpO<sub>2</sub>/HR value and the time value at the point where the cursor resets. Moving the cursor back and forth this way, you can view the SpO<sub>2</sub>/HR trend (12/24/96 hours long). Press "OK" key again to exit trend viewing.
- When pressing "Up" or "Down" key to move the cursor, the increment is variable. The rule is that the initial step is 1, after pressing the "Up" or "Down" key in the same direction 5 times, the step becomes 5, and with 5 more pressing the step becomes 10, then 20. Pressing the other "Up" or "Down" key will revert the step back to 1 in the other direction.
- Long press the "OK" key to bring up a dialogue for deleting data records, where the user can choose to delete all trend data.

- 
- Short press the print "" key to print this trend graph.

## 4.9 Setup Menu Screen

The Setup Menu screen is the main menu screen and a long press of Display View "" key will enter into the Setup Menu screen, as shown in Figure 4.10.

Note: your monitor may not cover all the functional parameter settings listed in the main menu screen. Please refer to the monitor you purchased.

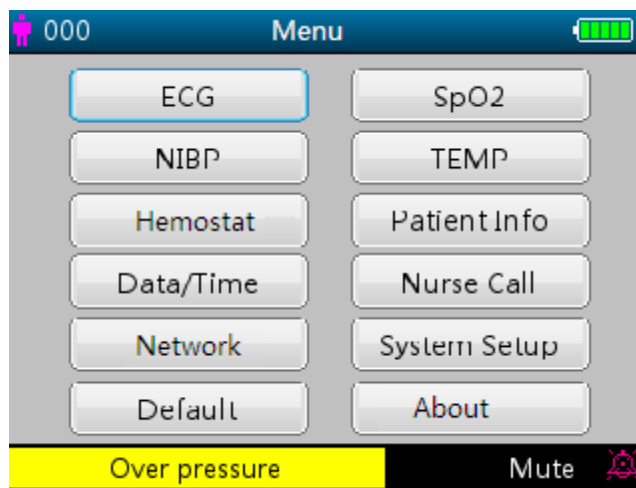





Figure 4.10 Root setup menu screen (refer to your monitor)

There are up to 12 functional groups for setting parameters: “ECG, SpO<sub>2</sub>, NIBP, TEMP, Hemostat, Patient Info, Date/Time, Nurse Call, Network, System Setup, Default and About” on the Setup Menu Screen depending on the configuration of your monitor.

### Instructions for navigation parameters:

1. Short press the "" or "" key to shift the cursor to corresponding functional group setting.
2. Short press the "" key to confirm and enter into the corresponding functional parameter setup screen.
3. Short press the "" to exit from the Setup Menu Screen.

Note: the device will save the latest setup settings automatically and the most of saved settings are non-volatile, i.e. when you shut down the device and power up it next time, every setting item shows the settings saved last time except the items like ECG cable setting and NIBP working mode.

## 4.9.1 ECG Setup (Optional)

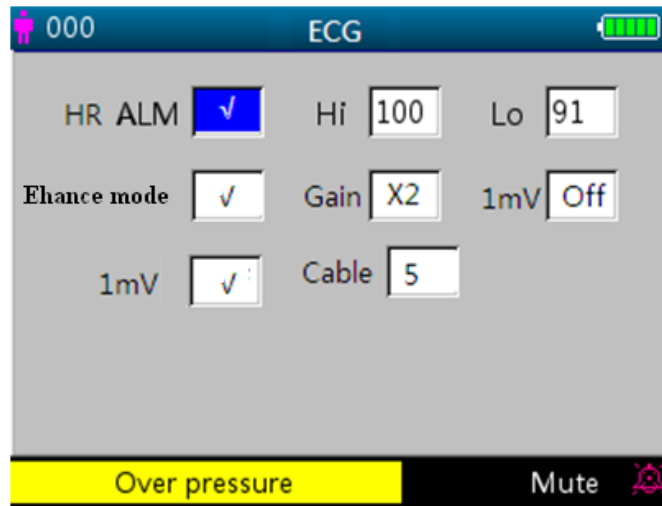

Figure 4.11 ECG setup

### Screen description:

- ✧ "HR ALM": heart rate alarm switch, this item is fixed to be "ON" and the user can not set it.  
Hi: high alarm limit for HR  
Lo: low alarm limit for HR
- ✧ "Lead": set ECG lead.
- ✧ "Gain": set ECG waveform gain, "X1, X2, X4, X1/2, X1/4" for optional.  
"X1": Waveform scale with base gain  
"X2": Twice scale size of the base gain.  
"X4": 4 times scale size of the base gain.  
"X1/4": 1/4 size of the base gain  
"X1/2": Half scale size of the base gain
- ✧ "1mV": the activation status of the internal 1mV calibration signal. Select "√" means activation of the internal 1mV calibration signal, select "×" means deactivate it. "√" means the ECG signal source will be the internally generated 1mV signal for calibration, and the calibration signal waveform (1mV, 1Hz square wave) will be displayed on the screen.
- ☞ The 1mV calibration signal is used to test the ECG function of the device. It is not used during normal operation.
- ✧ "Enhance mode": the switch of filter mode. Select "√" means enhance mode for the filter with extended bandwidth (0.05Hz~40Hz), select "×" means filter with normal bandwidth (0.5Hz ~ 40Hz).
- ✧ "Cable": choose the number of lead wires for ECG cable to be used. "3" and "5" for optional. Only lead I, II and III can be selected if "3" lead wires is set. All ECG leads including lead I, II, III, aVR, aVL, aVF, V (V1~V6) can be selected if "5" leads wires is set. The factory default is "3".

### Instructions for setting parameters:

1. Press "▲" or "▼" keys to move the cursor to select parameters. The parameter that the cursor rests on will turn to yellow. Short press the OK "■" key, to set the selected parameter and the selected parameter will turn to blue.
2. Short press the "▲" or "▼" again to adjust or modify parameter values. Short press the OK "■" key again to confirm and save the setting.
3. Short press the "□" key to return to upper level screen.

**Note:** operation for each parameter setting is similar to ECG setup, so we will not cover it again.

## 4.9.2 SpO<sub>2</sub> Setup (Optional)

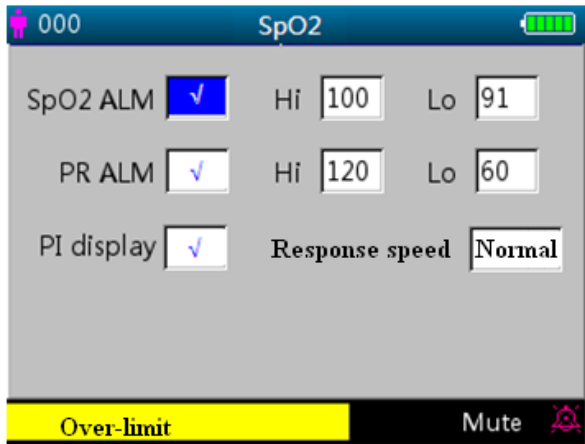

Figure 4.12A SpO<sub>2</sub> Setup Screen



Figure 4.12B SpO<sub>2</sub> Setup Screen (with Masimo SpO<sub>2</sub> configuration)



Figure 4.12C SpO<sub>2</sub> Setup Screen (with Nellcor SpO<sub>2</sub> configuration)

The SpO<sub>2</sub> setup screen is as shown in figure 4.12A or 4.12B, please refer to the monitor in your hand.

### Screen Description:

- ✧ “SpO<sub>2</sub> ALM”: SpO<sub>2</sub> alarm switch; This is set "ON" and the user cannot adjust it.  
“Hi/Lo”: high and low alarm limit for SpO<sub>2</sub>.
- ✧ “PR ALM”: pulse rate alarm switch..This is set "ON" and the user cannot adjust it.  
“Hi/Lo”: high and low alarm limit for PR.
- ✧ “PI% display”: PI display switch. "√" means PI display is enabled, "×" means PI display is disabled.
- ✧ "Response speed": "Normal", "Steady" and "Fast" for optional. Note: this setting item is optional, please refer to the monitor you purchased.
- ✧ AvgTime (only for Masimo SpO<sub>2</sub> is configured): The signal averaging time of the oximetry can be set to: 2, 4, 8, 10, 12, 14 and 16 seconds. For the 2 and 4 second settings the averaging times may range from 2-4 and 4-6 seconds, respectively. The default is 8. The stability of the SpO<sub>2</sub> and PR readings over time is affected by the averaging mode being used. The longer the averaging time, the more stable the readings tend to become. This is



due to a dampened response as the signal is averaged over a longer period of time than during shorter averaging times. However, longer averaging times delay the response of the oximeter and reduce the measured variations of SpO<sub>2</sub> and PR.

- ✧ **FastSat** (only for Masimo SpO<sub>2</sub> is configured): There are 2 options: "ON" and "OFF". Select "ON" to activate the FastSat algorithm. With FastSat the averaging time is dependent on the input signal. In the 2 and 4 seconds averaging mode, the FastSat algorithm is automatically enabled. The default is "OFF".
- ✧ **Sensitive** (only for Masimo SpO<sub>2</sub> is configured): Rotate the knob to toggle between the Normal, APOD and Maximum Sensitivity modes. Use the Normal Sensitivity setting for typical monitoring purposes. Use the APOD setting where there is a high probability of the sensor becoming detached. Use the Maximum Sensitivity setting for patients with low perfusion or when the low perfusion message is displayed on the screen in APOD or normal sensitivity mode. The default is APOD.
- ✧ **SmartTone** (only for Masimo SpO<sub>2</sub> is configured): SmartTone is a feature that affects pulse beep and Signal IQ waveforms. When the SmartTone feature is ON, the Masimo SET<sup>®</sup> algorithms will continue to provide pulse beep and Signal IQ waveforms even the plethysmogram is noisy due to motion or low signal conditions. With SmartTone OFF, the pulse beep and signal IQ waveforms will suppress beep information during periods of motion or low signal conditions. The default is OFF.
- ✧ **“SatSeconds”** (only for Nellcor SpO<sub>2</sub> is configured): SatSeconds provides a proprietary alarm management technique to help reduce false and nuisance alarms when using pulse oximetry. This function can be activated by selecting a Sat limit. “0” (Zero means that SatSeconds alarm management turns OFF), “10”, “25”, “50” and “100” are optional.

NOTE: 1. The SatSeconds icon may be filled in the clock-wise direction beginning at the 12 o'clock position. The icon may fill in increments using a ratio of the current SatSeconds value to the current SatSeconds setting.

2. When the SatSeconds value reaches to the setting SatSeconds (such as “50”), the SatSeconds circle icon will become a red rectangle with a black circle in it (like “”), meanwhile SpO<sub>2</sub> alarm is activated.

3. SatSeconds value = Saturation points \* Seconds.

### 4.9.3 NIBP Setup (Optional)

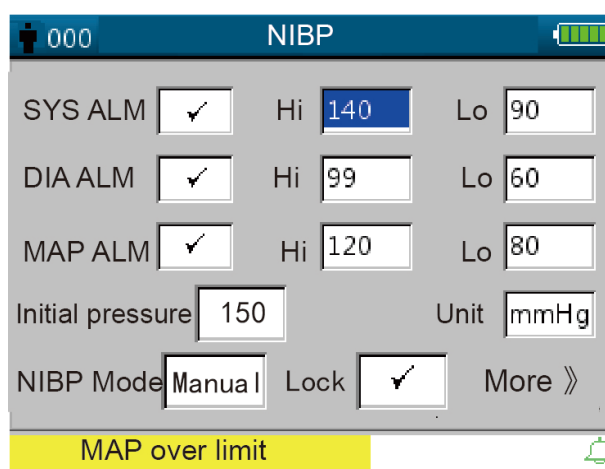

Figure 4.10 NIBP Setup

---

### NIBP Setup Screen Description:

SYS ALM, DIA ALM, MAP ALM are set "ON" and the user cannot adjust them.

- ✧ **“SYS ALM”**: systolic pressure alarm switch.  
    **“SYS Hi/Lo”**: high and low alarm limit for systolic pressure
- ✧ **“DIA ALM”**: diastolic pressure alarm switch.  
    **“DIA Hi/Lo”**: high and low alarm limit for diastolic pressure.
- ✧ **“MAP ALM”**: mean arterial pressure alarm switch.  
    **“MAP Hi/Lo”**: high and low alarm limit for mean arterial pressure.
- ✧ **Initial pressure**: Initial cuff inflation pressure to be inflated initially, its range is different depending on patient type.

**for neonates**: initial inflation pressure: setting range: 60~80 mmHg; default value: 70 mmHg.

**for pediatrics**: initial inflation pressure: setting range: 80~140 mmHg; default value: 120 mmHg.

**for adults**: initial inflation pressure: setting range: 80~200 mmHg; default value: 150 mmHg.

Note: if the device is configured with SunTech blood pressure module, then the initial inflation pressure setting range for adult is 120~200mmHg.

Note: In order to avoid inappropriate initial inflation pressure values which may cause harm to patients, when the patient type, measuring mode or patient ID is changed, the inflating pressure value will rollback to the latest setting value.

- ✧ **"Unit"**: the pressure unit. mmHg and kPa for optional.
- ✧ **“NIBP Mode”**: NIBP measuring mode, "STAT", "Manual", "CUSTOM", "AUTO 1", "AUTO 2", "AUTO 3", "AUTO 4", "AUTO 5", "AUTO 10", "AUTO 15", "AUTO 20", "AUTO 30", "AUTO 40", "AUTO 50", "AUTO 60", "AUTO 90", "AUTO 120", "AUTO 240 and "AUTO 480" are optional. When "STAT" is selected, the device will take a short-term (5 minutes) automatic NIBP measurement. "AUTO 1" means NIBP measurement takes once every minute automatically; "AUTO 480" means NIBP measurement takes once every 480 minutes automatically; In AUTO mode, the count-down timer is displayed in MAP (Time) segment on upper right corner.

Note: when "STAT" (short-term automatic NIBP measurement) mode is selected, the LED display segments for MAP value will change to display "STAT" confirming the current NIBP mode, therefore the MAP value will not be displayed. When the "STAT" mode finishes after 5 minutes (or measurement error occurs or it is interrupted manually), then the device will shift into "Manual" mode automatically.

- ✧ **“Lock”**: select “√” means that the cuff inflation pressure is locked at the initial setting value. After “Lock” item is selected, the cuff inflation pressure will not adapt according to the last NIBP measurement result, it will be fixed at the preset initial inflation pressure when you make the following NIBP measurement.
- ✧ **"More >> "**: page down icon. Move the cursor to the last item ("Lock"), then short press the Down " " key to enter into NIBP verification setup screen, as shown in figure 4.14.

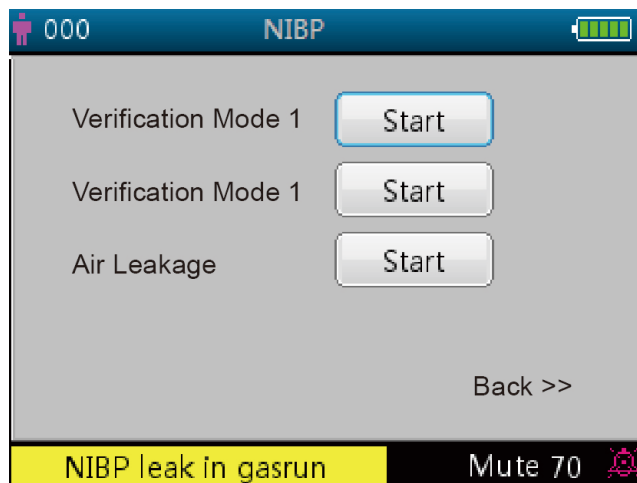

**Figure 4.14 NIBP verification setup screen**

**Screen description:**



- ✧ "Verification mode 1": Pressure is generated automatically by the internal pump. Move the cursor to NIBP Verification mode 1 "Start" button, and press the OK button to begin the pressure meter verification. (During this process, the "Start" shifts to "Stop", after the verification the "Stop" shifts to "Start").
- ✧ "Verification mode 2": Pressure is coming from an external source. Move the cursor to NIBP Verification mode 2 "Start" button and press the OK key to begin the pressure meter verification. (Again, the "Start" shifts to "Stop" during this process, after the verification the "Stop" shifts to "Start").
- ✧ "Air leakage": Checks the air leakage in the pneumatic system. Move the cursor to Air Leakage "Start" button, then press the OK key. The pump inflates to certain pressure and then the valve will be closed to detect leakage for 10 seconds. The pressure will be released automatically and the screen will display the result
- ✧ If the following messages pop up, then NIBP measurement should be stopped.
  - 1) Pressure verification...
  - 2) Air leakage preparing...
  - 3) Air leakage countdown...
  - 4) Air leakage in 10s:...

**Safety instruction:**

☞ The NIBP calibration and Air leakage detection can only be carried on when the NIBP measurement is set to mode "Manual".

**NIBP setup screen description:**

Short press the NIBP setup " key to enter into NIBP setup screen, as shown in figure 4.15.

In NIBP setup screen, short press the " key to select measuring mode. Press NIBP measuring " key to confirm the setting and exit from setup screen. Short press the display view " key to exit. Press up/down keys to select patient type.

- ✧ **NIBP Mode:** select NIBP measuring mode.

When "STAT" (short-term automatic NIBP measurement) mode is selected, the LED display segments for MAP value will change to display "STAT" prompting the current NIBP mode, therefore the MAP value will not be displayed. When the "STAT" mode finishes 5 minutes (or measurement error occurs or it is interrupted manually), then the device will shift into "Manual" mode automatically.

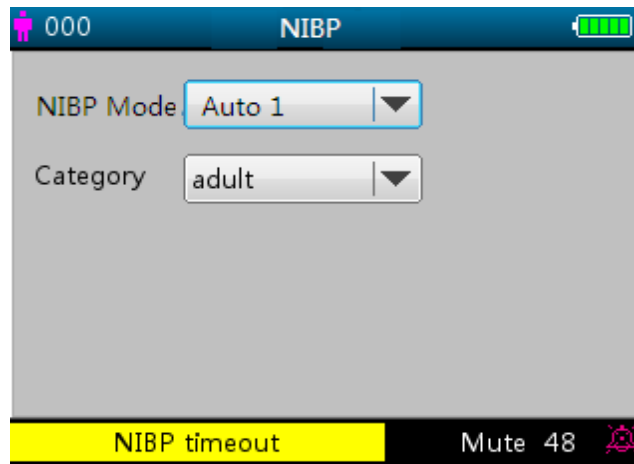

Figure 4.15 NIBP setup screen

#### 4.9.4 TEMP Setup (Optional)

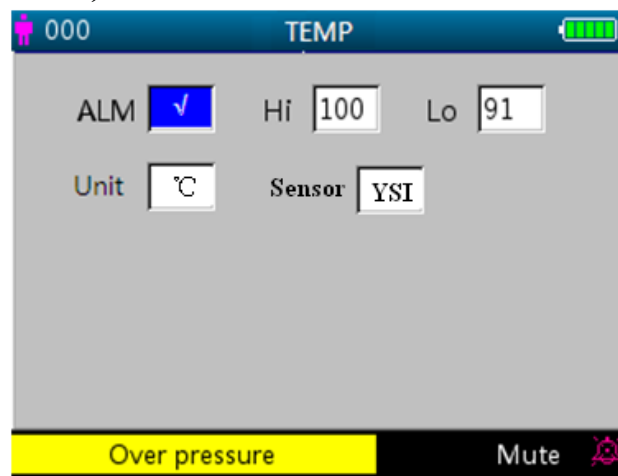

Figure 4.16 TEMP setup screen

#### Screen Description:

- ✧ **TEMP ALM:** temperature alarm switch. This item set ON, and the user cannot adjust it.  
"Hi/Lo": high and low alarm limit setting for temperature.
- ✧ "Unit": set the temperature unit, "°C" and "°F" can be optional.
- ✧ "Sensor": temperature sensor type, "KRK" and "YSI" can be selected. Please set the sensor type according to the sensor in use, or the temperature measurement will fail or be inaccurate.

#### 4.9.5 Hemostat Setup (Optional)

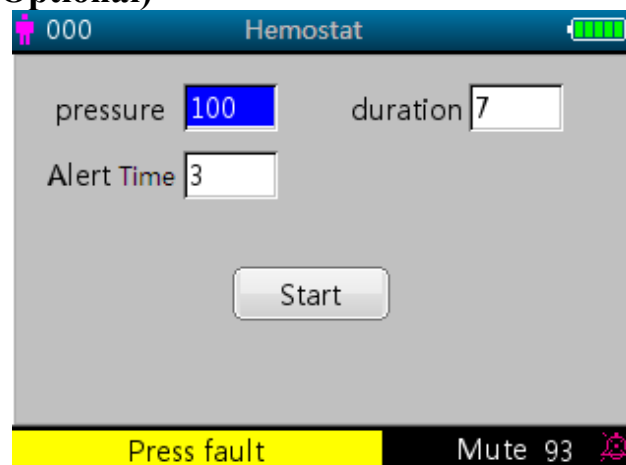

Figure 4.17 Hemostat setup screen

---

### Hemostat Setup Screen Description:

- ✧ **“Pressure”**: when you use hemostat function, you need to preset a cuff pressure for hemostasis. The pressure is adjustable, and its adjusting limit is different for different patient category:

**for neonates**: preset range: 70~100 mmHg, default value: “90” mmHg;

**for pediatrics**: preset range: 80~130 mmHg, default value: “110” mmHg;

**for adults**: preset range: 80~180mmHg, default value: “140” mmHg.

If the pressure drops down slowly under 10mmHg compared with the preset value due to little air leakage in the pneumatic system when time passes by, the monitor will re-inflate to maintain the cuff pressure close to the preset pressure value.

**Note**: the unit of cuff pressure is the same with the NIBP unit in NIBP Setup.

- ✧ **“Duration”**: After presetting the cuff pressure, you need to set the time period for maintaining the preset pressure after inflation. “5, 6, 7,...120” minutes adjustable. The default value is “40” minutes.

If the set value is “xx” minutes, the monitor will count down from “xx” minutes automatically when starting cuff inflation. When time is up, it will deflate automatically.

- ✧ **“Alert Time”**: the alert time for reminding user that the operation of hemostat is going to be end after this time period. 1 to 60 minutes adjusting range with 1 minute step, the default value is “5” minutes. If the set value is “xx” minutes, the monitor will produce alarm sound until ending deflation when counting down time reaches to “xx” minutes. The alarm type is high priority alarm. (For example: the duration is 40 minutes, the alert time is 5 minutes, the alarm will ring for prompt when the duration counting down to 5 minutes. The Prompt Info area starts to prompt: Hemo C-D 300 seconds.)

**“Start”**: shift cursor to “Start” and press “” key, “Start” becomes “Stop” and meanwhile the blood cuff starts being inflated; Pressing “Stop” button can stop using this function. After deflation, it will change to “Start” again.

### 4.9.6 Patient Info

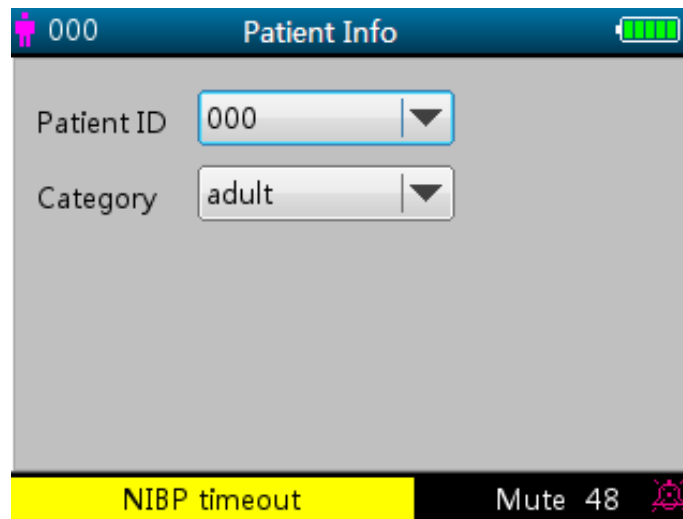

Figure 4.18 Patient Info. setup screen

#### Screen description:

- ✧ **“Patient ID”**: change or set current patient’s ID number, 0~100 adjustable; Once the patient ID is changed, the history data in trend graph will be cleared, and the parameter settings will be resumed to default value.
- ✧ **“Category”**: change or set the category of current patient; three options “adult”, “pediatric” and “neonate”, press OK key to confirm the setting and the patient type indicator will be ON at the front panel of the device. The default is “adult”.

---

## 4.9.7 Date/Time Setup

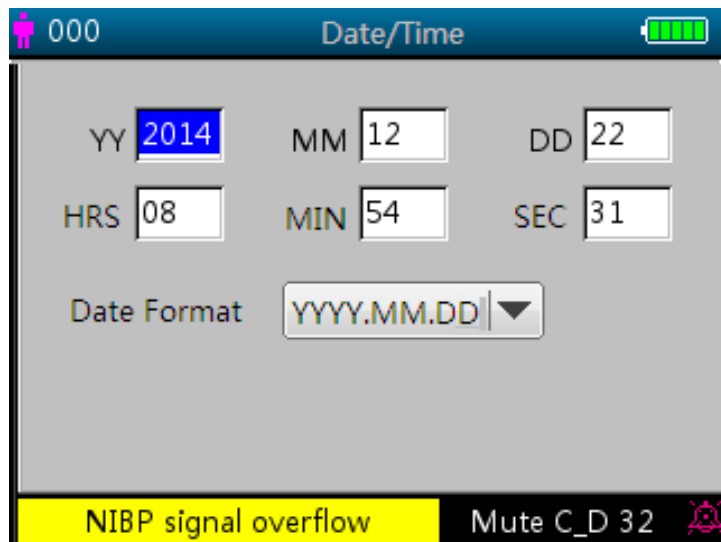

Figure 4.19 Data/Time Setup Screen

### Screen Description:

- ✧ “YY 2014 MM 12 DD 22”: date setting.
- ✧ “HRS 08 MIN 54 SEC 31”: time setting.
- ✧ **Date Format:** 4 options.
- ✧

## 4.9.8 Nurse Call Setup

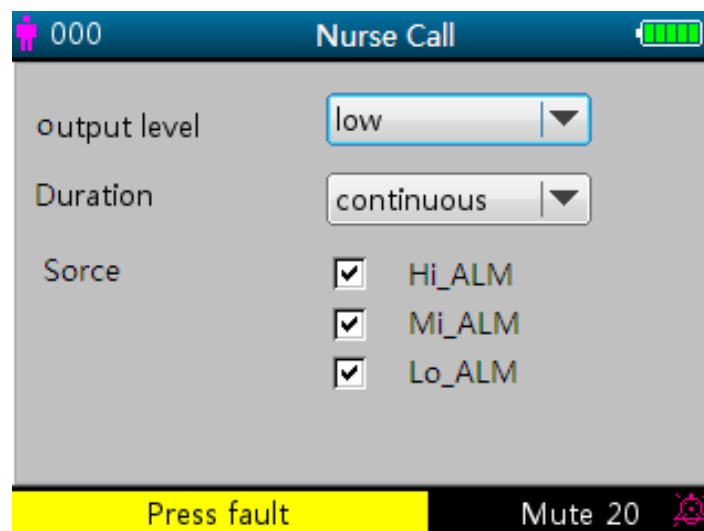
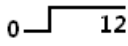

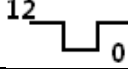

Figure 4.20 Nurse Call Setup Screen

### Screen Description:

- ✧ “**Output level**”: two options “low” or “high” output levels are available.
- ✧ “**Duration**”: two options “pulse” and “continuous” output modes are available with the Output level and

Duration shown below.

| Output level | Duration   | Output (format)  |
|--------------|------------|--|
| High         | Continuous | 0  12 |
| Low          | Pulse      | 0  12 |
| High         | Continuous | 12  0 |
| Low          | Pulse      | 12  0 |

✧

- ✧ **“Source”**: three kinds of alarm sources can trigger the nurse call: high level alarm, medium level alarm and low level alarm (multi-optional). After selecting the alarm level, the device will send out the nurse call signal according to "Source" and "Output level". If you don't select any source, nurse call signal will not be generated (Note: multiple "Source" selection can be chosen.)

**Note:** Nurse Call function cannot be regarded as the main alarm notification method, please do not rely on it alone. You should combine parameter values with alarm level and patient's clinical behavior and symptom to determine patient's condition

#### 4.9.9 Network Setup (Optional)

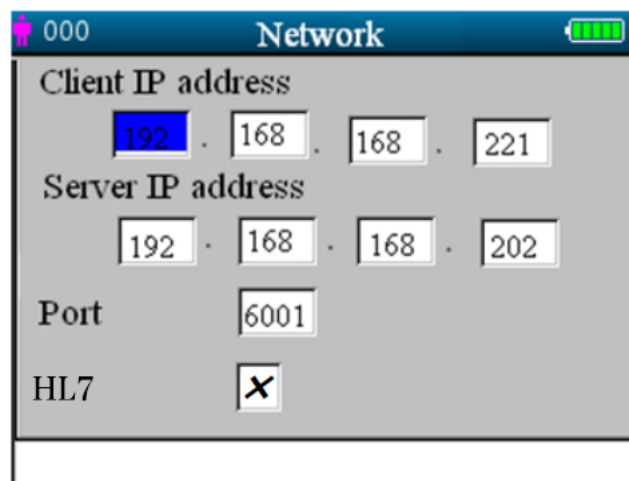

Figure 4.21 Network setup screen

##### Screen description:

- ✧ "Client IP address": sets the IP address of this monitor, which acts as a client in the network system.
- ✧ "Server IP address": sets the IP address of the remote server, which is Central Monitoring System to be connected.
- ✧ "Port": the remote port number to which the monitor will connect to the work station in the Central Monitoring System. Its setting range is from 6001 to 6064. It can also be used to represent the patient bed number connecting to the work station. For example, the port number 6002 means the monitor is assigned to the bed number 2 in the CSM. The work station can connect to up to 64 bedside monitors, so please set the port number between 6001 and 6064. Press Knob to make the new setting effective.
- ✧ "HL7": Sets to enable or disable the network service by HL7 protocol. Selecting "√" means the monitor will work as a server allowing access from the remote client by HL7 protocol, meanwhile the monitor will disconnect from the work station in the Central Monitoring System. Selecting "X" means the monitor will work as a client connecting to the CMS, and will not provide network service with HL7 protocol. The factory default is CMS network function (HL7 service disabled).

Note: 1. Make sure that remote Server and the monitor are located in the same network segment. Every monitor should have its unique Port Number. Otherwise, network connection will be failed anytime.

2. The icon  (on the lower right corner of screen) displays the network status.

## 4.9.10 System Setup

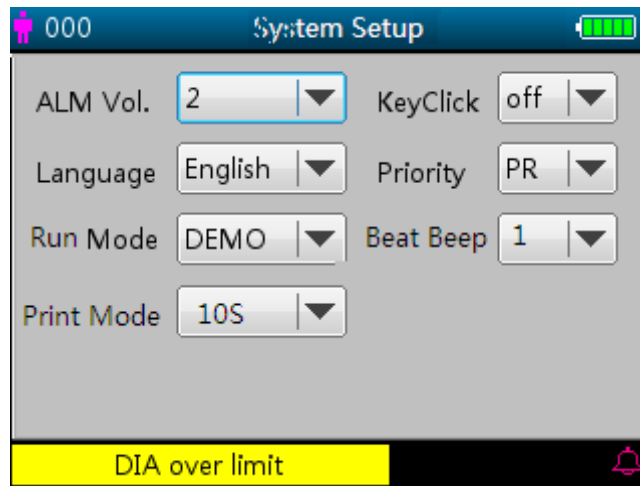

Figure 4.22A System Setup Screen

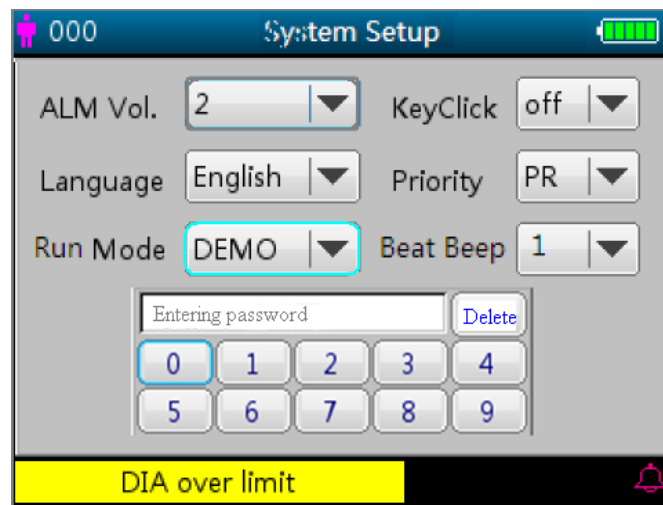

Figure 4.22B System Setup Screen

### Screen Description:

- ✧ **“Alarm Vol.”:** sets alarm volume, adjustable from level “1~10” with a factory default of 5. It is recommended that the alarm volume shouldn’t be set lower than the factory default value unless the nursing personnel attends the patient and the device at all times.
- ✧ **“Key tone”:** turns on/off the key tone, the default is "ON".
- ✧ **“Language”:** language selection. “ENG” for English.
- ✧ **“Priority”:** this item is nonadjustable, fixed to give priority to the “HR” value display.
- ✧ **“Run mode”:** "Real" should be set as default use. "Demo" only for demonstration purpose. Changing this item requires a password, the default password is "1234".

“Demo” shows a demonstration waveform and data, which are generated by the monitor.

“Real” shows the real signal waveform and data coming from patient, i.e. normal working state.

- ✧ **"Beat beep":** adjusts the volume of the pulse beeping sound and is adjustable from level “0~7”. “0” switches off the pulse beep sound, the factory default is set at "2". The tone of pulse beat beep changes when the measured SpO<sub>2</sub> changes i.e. the higher the SpO<sub>2</sub> value is, the higher the tone of the pulse beep (which becomes sharper); and the lower the SpO<sub>2</sub> value is, the lower the tone of the pulse beep.



- 
- ✧ "Print Mode": sets the printing time for real-time printing mode with the options of "Continue", "10s", "20s", "30s" and "60s" for optional. "Continue" means that the device will not stop printing the real-time plethysmogram and ECG waveform until the user change the display screen or press the print key again.

XXs: prints the real-time plethysmogram and ECG waveform lasting for XX seconds.

Note: the gray background means this item is nonadjustable.

### 4.9.11 Reset to Factory Default Settings

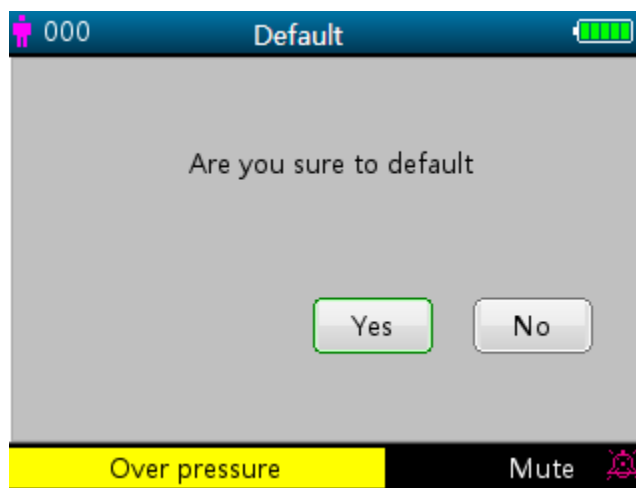

Figure 4.23 Default setting

### 4.9.12 About

This displays the software version and serial number, as shown in figure 4.24, refer to the monitor for detailed information.

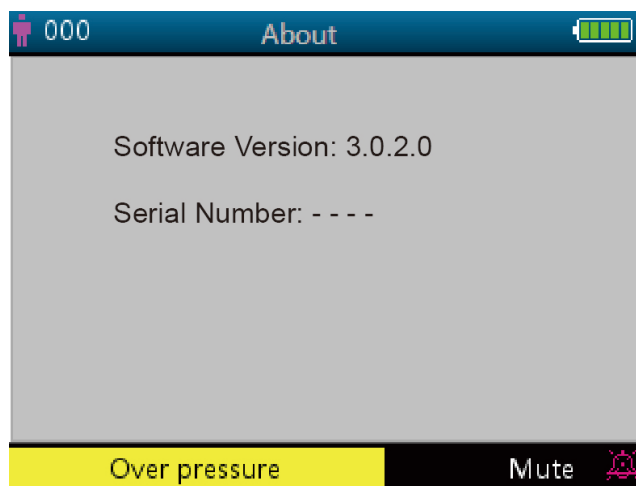

Figure 4.24 About

---

## 4.10 Alarm Settings

Press the alarm silence "🔔" key to set the alarm sound status.

There are 3 options in total:

- ✧ Alarm sound is enabled, which is the default status..
- ✧ Short term alarm silence (120 seconds): a short press of the alarm silence key will display the red icon "🔔" on the lower screen and the message "silence count-down time 120". At this time, the alarm silence indicator on the left side of the alarm silence key will be lit. The device will mute the alarm sound temporarily for 2 minutes, but keep the visual alarm flashing. When the time (120s) is up, the alarm silence will be de-activated automatically, the red icon "🔔" will disappear as well, and the alarm silence indicator will be dark.
- ✧ Long term alarm silence: long press the alarm silence key will be display the red icon "🔔" on the lower screen and the alarm silence indicator on the left side of the alarm silence key will be lit. The device will mute the alarm sound on an ongoing basis but keep the visual alarm flashing until a new type of alarm event is detected. The alarm silence status will then be terminated automatically and the alarm sound will resume, the red icon "🔔" will disappear as well, and the alarm silence indicator will be dark.

Note: If the current status is alarm silence, a long or short press of the alarm silence key can de-activate the alarm silence function.

## 4.11 Data Uploading

When connected to a computer via USB, the device enters into data uploading mode, as shown in figure 2.25.

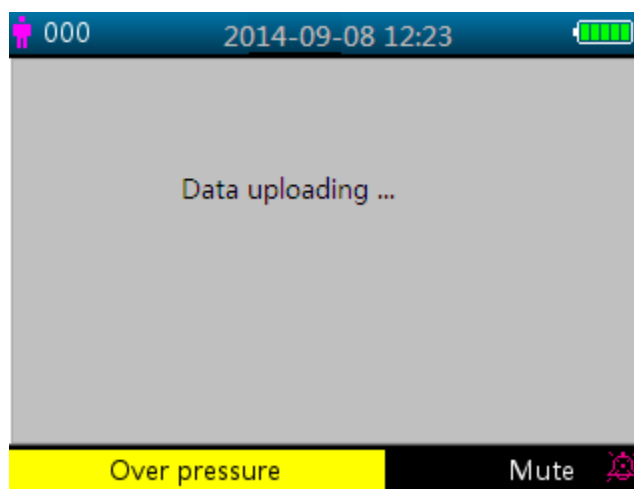

**Figure 4.25 Data uploading screen**

In data uploading mode, the device will automatically stop SpO<sub>2</sub> measurement, NIBP measurement, Hemostat, pressure verification and air leakage checks etc., and all key operations will be disabled except power "🔋" key.

---

## Chapter 5 Alarms

### 5.1 Alarm Priority

#### Low Priority:

NIBP over range  
Temp over range  
PR over range  
ECG Lead off  
SpO<sub>2</sub> Probe off  
Temp Probe off  
NIBP Measuring frequently, Stop!  
SpO<sub>2</sub> No Sensor  
SpO<sub>2</sub> Defective Sensor  
SpO<sub>2</sub> Low Perfusion  
SpO<sub>2</sub> Pulse Search  
SpO<sub>2</sub> Interference  
SpO<sub>2</sub> Sensor Off  
SpO<sub>2</sub> Too Much Ambient light  
SpO<sub>2</sub> Unrecognized Sensor  
SpO<sub>2</sub> Low SIQ  
SpO<sub>2</sub> No Cable  
SpO<sub>2</sub> No Sensor  
SpO<sub>2</sub> Demo Mode  
SpO<sub>2</sub> Failure  
Pressure fault  
Cuff error  
Air leakage  
Excessive motion  
Over pressure  
Pressure saturation  
Air leakage detected  
BP signal weak  
BP over range  
BP function fail  
BP measuring timeout  
SpO<sub>2</sub> malfunction  
SpO<sub>2</sub> software error  
SpO<sub>2</sub> comm error  
SpO<sub>2</sub> faulty sensor  
SpO<sub>2</sub> error need Logged  
SpO<sub>2</sub> sensor comm error  
SpO<sub>2</sub> INOP  
Unrecognized SpO<sub>2</sub> Sensor

---

**Medium Priority:**

HR over range

**High Priority:**

Low battery

SpO<sub>2</sub> over limit

SYS over limit

DIA over limit

MAP over limit

Temp over limit

PR over limit

HR over limit

RR over limit

Unable to detect SpO<sub>2</sub>

Unable to detect HR

Timing:

## 5.2 Alarm Signal Generation

When there is alarm condition, the monitor generates alarm signal with visual indications (which are shown by two ways: LED indicator with different color and textual message display) and audible indication.

### Visual Alarm Indication

The flashing rates for the three categories of alarms are shown in the table below.

| LED Indicator Color | Alarm Category        | Flashing Rate              |
|---------------------|-----------------------|----------------------------|
| Red flashing        | High priority alarm   | 2 Hz                       |
| Yellow flashing     | Medium priority alarm | 0.5 Hz                     |
| Yellow light        | Low priority alarm    | Constant(on)(non-flashing) |

Table 5.1

Refer to Chapter 11.2 Alarm Information for detailed alarm message descriptions.

### Audible Alarm Indication

The audible alarm has different tone pitch and on-off beep patterns for each priority category. These are summarized in the table below.

| Alarm Category        | Tone Pitch | Beep Chain            |
|-----------------------|------------|-----------------------|
| High priority alarm   | ~400Hz     | 10 beeps pause 3 sec. |
| Medium priority alarm | ~500Hz     | 3 beeps pause 5 sec.  |
| Low priority alarm    | ~500Hz     | Single beep           |

Table 5.2

**Note:** Visual alarm indication can not be suspended or removed. Audible alarms may be decreased in volume or silenced as described.

---

## 5.3 Alarm Reset and Silence

Press  (Alarm Silence) key to pause the audible alarm temporarily or reset the current alarm condition. During the monitoring process, press "Alarm Silence" key shortly to start the alarm silence for 2 minutes. The counting down time shows up on the upper left corner of the screen once the alarm silence is activated. Long pressing "Alarm Silence" key will reset the current alarm condition, that means the sound mute for this alarm will not resume unless another alarm condition occurs. During the alarm silence period, if there is a new alarm condition other than the current one occurs, the device will generate the audible alarm indication again automatically. After the end of alarm silence period, if the current alarm condition still exists, then the audible alarm indication will resume as well.

When the monitor generates alarms, the user can press  key to reset or pause the audible alarm indication for a given silence period when necessary..

🔔 **DO NOT silence the audible alarm or decrease its volume if patient safety could be compromised.**

🔔 For the alarm conditions of "Can not detect SpO<sub>2</sub>" and "Can not detect HR/PR", the audible alarm indication will only last for about 7 seconds.

🔔 Alarm signal can be reset, but it can NOT be deactivated all the time.

## 5.4 Alarm Settings

- 1、 Except volume of audible alarm can be adjustable, the other properties of the alarm signal cannot be adjusted by the user, such as alarm priority setting, alarm light flashing and so on. In addition, all alarms in this patient monitor are "non-latched" type, that is to say, when the alarm condition does not exist, the corresponding alarm signal will automatically stop.

The alarm volume range is shown as below:

- ◇ High: 45dB~80dB (The distance from the front of device to the test instrument is 1m)
- ◇ Medium: 45dB~75dB (The distance from the front of device to the test instrument is 1m)
- ◇ Low: 45dB~70dB (The distance from the front of device to the test instrument is 1m)

- 2、 When the icon  displays on the screen and its color is red, that means the alarm volume is 0 (alarm is mute), at this time the user should pay more attention to the patient.

 It is suggested that the users should not change the alarm volume lower than the factory default setting if close and constant attention could not be paid to the patient, otherwise the negligence of alarm event might cause irreversible harm to the patient.

 During the alarm silence period, any new alarm event can activate the audible alarm again and the audible alarm function resumes normal state.

 After the alarm silence time counts down to 0, or the operator presses the Alarm Silence Key again, then the system will resume to the audible alarm signal if this alarm condition still exists.

 The alarm limit value should NOT be set to exceed the declared measuring or display range, or the system alarm signal will not be generated.

- 3、 Alarm settings are non-volatile, that means the previous settings will still sustain if the patient monitor is powered off (by accidental power interrupt or by normal power down) and reboot.
- 4、 When pressing the Alarm Silence Key, the system will stay on "Alarm Silence" status and this status will last for 2 minutes.
- 5、 It takes only 1 second from canceling alarm silence to resuming alarm sound .

Long press of Display View "  " key to enter into the Setup Menu screen, and move the cursor to each parameter

---

(such as SpO<sub>2</sub>, NIBP...) to make the high/low limit setting.

☞ Limits setup: Move to the High or Low limits of the alarm settings, and press the “Alarm” silence key to turn ON or OFF the alarm for the setting. The alarm silence indicator will reflect this with a yellow light showing that alarms are silenced.

Refer to Chapter 11.2 for detailed default alarming values of all parameters and setup range.

- **Whenever the monitor is used, check the alarm limits to ensure that they are appropriate for the patient being monitored.**
- **When mains power supply is lost for not more than 30s, the alarm settings prior to the power interrupt will sustain or be restored automatically.**

## 5.5 Verifying Alarm Function

To verify the effectiveness of the alarm function, set the monitor working at “Demo” mode in system parameter settings menu. Adjust the alarm limits or change alarm setting, then pay a close attention to the alarm signal. If the visual and audible alarm indications appear according to your setting, it means the alarm function is effective. Do NOT set the alarm volume lower than the background noise.

# Chapter 6 Technical Specifications

## 6.1 ECG Monitoring

1. Input signals range in amplitude:  $\pm (0.5 \text{ mVp} \sim 5 \text{ mVp})$
2. Heart rate display range: 15 bpm  $\sim$  350 bpm
3. Heart rate display accuracy:  $\pm 1\%$  or  $\pm 2$  bpm, whichever is greater.
4. Heart rate averaging: Averages the recent eight beats having RR intervals falling within the acceptable limits.
5. Heart rate alarm delay time:  $\leq 10\text{s}$
6. Response time to change in heart rate:
  - Change from 80 bpm to 120 bpm:  $< 8 \text{ sec}$
  - Change from 80 bpm to 40 bpm:  $< 8 \text{ sec}$
7. Tall T-wave rejection: Rejects all T-wave less than or equal to 120% of 1mV QRS.
8. Sensitivity selection:
  - $\times 1/4$ , 2.5mm/mV tolerance:  $\pm 5\%$
  - $\times 1/2$ , 5mm/mV tolerance:  $\pm 5\%$
  - $\times 1$ , 10mm/mV tolerance:  $\pm 5\%$
  - $\times 2$ , 20mm/mV tolerance:  $\pm 5\%$
9. Sweeping speed: 25mm/s tolerance:  $\pm 10\%$
10. ECG noise level:  $\leq 30\mu\text{V}_{\text{P-P}}$ .
11. ECG input loop current:  $\leq 0.1\mu\text{A}$
12. Differential input impedance:  $\geq 10\text{M}\Omega$
13. Common-mode rejection ratio (CMRR):  $\geq 105\text{dB}$
14. Time constant:  $\geq 3.2\text{s}$  for enhance mode  $\geq 0.3\text{s}$  for normal mode
15. Frequency response: 0.05Hz~40 Hz for enhance mode 0.5Hz~40Hz for normal mode

| <b>Additional declarations to conform the particular standard of IEC 60601-2-27 “Medical electrical equipment – Part 2-27: Particular requirements for the safety, including essential performance electrocardiographic monitoring equipment”</b> |  |                              |
|---|--|------------------------------|
| <b>Direct current for respiration, leads-off sensing, and active noise suppression</b>  | Applied current less than 0.1 microamperes.  |                              |
| <b>Response to irregular rhythm</b>   | A1 Ventricular bigeminy-80BPM<br>A2 Slow alternating ventricular bigeminy-60BPM<br>A3 Rapid alternating ventricular bigeminy-120BPM<br>A4 Bidirectional systoles-90BPM |                              |
| <b>Time to ALARM for tachycardia</b>  | <u>Waveform B1, Amplitude</u>  | <u>Average Time to Alarm</u> |
|   | 0.5 mV   | <8 sec                       |
|   | 1 mV   | <8 sec                       |
|   | 2mV  | <8 sec                       |
|   | <u>Waveform B2, Amplitude</u>  | <u>Average Time to Alarm</u> |
| 1mV   | <8 sec   |                              |
| 2mV   | <8 sec   |                              |
| 4mV   | <8 sec   |                              |

---

## 6.2 TEMP Monitoring

1. TEMP measuring range: 21.0°C~50.0°C
2. TEMP measuring accuracy: not greater than 0.2 °C for TEMP measuring range from 25.0°C~45.0 °C
3. TEMP responding time: ≤150s for KRK sensor; ≤40s for YSI sensor

## 6.3 NIBP Monitoring

1. Measuring method: Oscillometric Technique
2. Pneumatic pressure measuring range: 0 mmHg~300mmHg
3. Accuracy of pressure measurement: ±3 mmHg
4. Cuff inflation time: <10 seconds (typical adult cuff)
5. Average measurement time: < 90 seconds
6. Air release time while the measurement is canceled: ≤2 seconds (typical adult cuff)
7. Initial cuff inflation pressure  
Adult: 175 mmHg      pediatric: 135 mmHg      Neonate: 65 mmHg
8. Overpressure protection limit  
Adult: ≤ 300 mmHg      pediatric: ≤ 240mmHg      Neonate: ≤ 150 mmHg
9. NIBP measurement range:

| press (unit) |      | Adult  | Pediatric | Neonate |
|--------------|------|--------|-----------|---------|
| SYS          | mmHg | 40~275 | 40~200    | 40~135  |
| MAP          | mmHg | 20~230 | 20~165    | 20~110  |
| DIA          | mmHg | 10~210 | 10~150    | 10~95   |

10. NIBP measurement accuracy:  
Maximal mean difference: ±5 mmHg  
Maximal standard deviation: 8 mmHg  
Measurement mode: Manual, Auto, STAT

## 6.4 SpO<sub>2</sub> Monitoring

1. Transducer: dual-wavelength LED  
Wavelength: Red light: 663 nm, Infrared light: 890 nm.  
Maximal optical output power: less than 2mW maximum average
2. SpO<sub>2</sub> measuring range: 35%~100%
3. SpO<sub>2</sub> measuring accuracy: Arms is not greater than 3% for SpO<sub>2</sub> range from 70% to 100%  
\*NOTE: Arms is the accuracy defined as root-mean-square value of deviation according to ISO 80604-2-61
4. Low perfusion performance: the declared accuracy is attained when the pulse amplitude modulation ratio is as low as 0.4%.

## 6.5 Pulse Rate monitoring

1. Pulse rate measuring range: 30bpm~240bpm
2. Pulse rate measuring accuracy: ±2bpm or ±2%, whichever is greater.

## 6.6 Data Recording

1. Sensitivity selection tolerance: ±5%
2. Recording speed: 25mm/s
3. Recording speed accuracy: ±10%



4. Hysteresis:  $\leq 0.5\text{mm}$
5. Frequency response: 0.5~40Hz for normal mode, 0.05~40Hz for enhanced mode.
6. Time constant:  $\geq 0.3\text{s}$  for normal mode,  $\geq 3.2\text{s}$  for enhanced mode.

## 6.7 Other Technical Specifications

1. AC power supply voltage: 100~240VAC
2. AC power frequency: 50/60 Hz
3. Battery specification: 11.1V/4400mAh (Li-ion Battery)

## 6.8 Operating Environment

### Working Environment

Ambient temperature range: 5°C ~ 40°C  
 Relative humidity: 30 ~ 80%  
 Atmospheric pressure: 70kPa ~ 106kPa

### Transport and Storage Environment

Ambient temperature range: -20°C ~ 60°C  
 Relative humidity: 10 ~ 95%  
 Atmospheric pressure: 50.0kPa ~ 107.4kPa

## 6.9 Classification

|   |                           |
|---|---------------------------|
| Safety standard                                 | IEC 60601-1               |
| The type of protection against electric shock   | Class I equipment.        |
| The degree of protection against electric shock | Type BF, CF applied parts |
| Electro-Magnetic Compatibility:                 | Group I, Class A          |

## 6.10 Other Technical Information

### 6.10.1 Additional description for ECG monitoring

1. Suppression against the interference from electro-surgical unit: this device has the proper capability to resist the interference from electro-surgical unit during ECG monitoring.
2. Heart rate average: Averages the recent eight beats having R-R intervals falling within the acceptable limits. The updating rate of the display: 1 time/second.
3. Heart rate meter accuracy and response to irregular rhythm:

| Input signal                                 | Detected HR (bpm) | Calculation formula     |
|--|-------------------|-------------------------|
| IEC60601-2-27Y2011(EF)<br>201.7.9.2.9 101 A1 | 80                | Calculate all QRS waves |
| IEC60601-2-27Y2011(EF)<br>201.7.9.2.9 101 A2 | 60                |                         |
| IEC60601-2-27Y2011(EF)<br>201.7.9.2.9 101 A3 | 120               |                         |
| IEC60601-2-27Y2011(EF)<br>201.7.9.2.9 101 A4 | 90                |                         |

4. Time to alarm for tachycardia:  $\leq 12\text{s}$
5. Pacemaker pulse rejection:  
 Can reject the no-overshoot pacemaker pulse: amplitude:  $\pm 2\text{mV} \sim \pm 700\text{mV}$ ; pulse width: 0.1 ms ~ 2 m

---

It's not applicable to overshoot pacemaker pulse.

6. Pacemaker pulse rejection for the ECG signal: the minimum input slew-rate is 2V/s RTI (it varies on different filter modes, ).
7. This device (including the accessories, such as Cuff, SpO<sub>2</sub> probe and the internal ECG module) is designed to have special protection against defibrillator.
8. When the device is used together with electro-surgical unit, the ECG signal display could return to its previous normal state within 10s after exposure to the field produced by the electro-surgical unit without loss of any stored data.
9. When the power line interference (50Hz/60Hz) is very high, the pacemaker pulse might be falsely detected.
10. Pacemaker pulse rejection warning label: see Section 3.4.3 & Section 8.1.
11. Auxiliary output: Not provided
12. Remote technology: Not provided

### 6.10.2 Additional description for SpO<sub>2</sub> monitoring

1. The device is calibrated in the factory before sale, so there is no need to calibrate it during its life cycle. Any SpO<sub>2</sub> simulators should not be used to validate the accuracy of the oximeter, they can only be used as functional testers to verify its precision. The SpO<sub>2</sub> accuracy claimed in this manual is supported by the clinical study conducted by inducing hypoxia on healthy, non-smoking, light-to-dark skinned subjects in an independent research laboratory.
2. If it is necessary to verify the precision of the oximeter routinely, the user can do the verification by means of SpO<sub>2</sub> simulator, or it can be done by the local third party test house. Please note that the specific calibration curve (so called R-curve) should be selected when use of SpO<sub>2</sub> simulator, e.g. for Index 2 series SpO<sub>2</sub> simulator from Fluke Biomedical Corporation, please set "Make" to "DownLoadMake: KRK", then the user can use this particular R-curve to test the oximeter. If the SpO<sub>2</sub> simulator does not contain "KRK" R-curve, please ask the manufacturer for helping to download the given R-curve into the SpO<sub>2</sub> simulator.
3. The average data update period: ≤10s

### 6.10.3 Additional description for NIBP measurement

The blood pressure measured by this device is essentially identical to that measured by auscultatory method.

### 6.10.4 Additional description for temperature measurement

This monitor adopts the thermistor-type probe to make temperature measurement. The constant micro direct current of the temperature probe is 32μA, and the dissipation power (I<sup>2</sup>R) is related to the probe type. If you choose KRK temperature probe, then the Static Power is less than 17 μW in the range from 15°C to 55°C; if you choose YSI temperature probe, then the Static Power is less than 3 μW in the range from 25°C to 45°C. The produced self-heating will not result in the measurement deviation exceeds the declared specification.

### 6.10.5 Additional description for alarm system

1. Alarm indication: audial and visual alarm signal
2. Audial alarm:
  - ◇ High priority alarm: one group pulse string including 10 pulse; x, x, 2x + td, x, 1s, x, x, 2x + td, x, and x=100ms, the pulse duration is 160ms, pulse frequency is 400Hz, the pulse string interval is 3s.
  - ◇ Medium priority alarm: one group pulse string including 3 pulse, the pulse string interval is y, y, and y=200ms, the pulse duration is 200ms, pulse frequency is 500Hz, the pulse string interval is 5s.
  - ◇ Low priority alarm: the unrepeatable single pulse, frequency is 500Hz, and pulse duration is 200ms.
3. Visual alarm: The visual alarm includes the LED indicator located on the upper front panel of the Monitor, the numeric readings flashing, and the alarm message displayed on the bottom of the LCD screen. Alarm indicator frequency and color see below:
  - Alarm LED indicator:** High-priority: red light flashing with 2Hz frequency and 50% duty ratio
  - Low priority: Yellow light flashing with 2Hz frequency and 50% duty ratio
  - Medium priority: Yellow light on
  - No alarm: Green light on

- 
- Numeric reading alarm:** the reading value flashing reversed color display
4. Alarm reset and silence: see Section 4.10.
  - 5.

### **6.10.6 Additional description for power supply, network and display**

1. Power supply: main power supply: AC 100V~240V, 50Hz/60Hz  
Internal power supply: 11.1VDC
2. Input power: <50VA
3. The minimum working time when operating with all accessories by internal power supply: 270min.
4. Network connection: Ethernet network
5. Display panel: color TFT LCD
6. Working modes: Demo mode and Real-time mode

## 6.11 Guidance and manufacturer's declaration-Electromagnetic compatibility

**Table 1**

### **Guidance and manufacturer's declaration-electromagnetic emission for all EQUIPMENT AND SYSTEM**

| <p>Gima Vital Pro Monitor is intended for use in the electromagnetic environment specified below.<br/>The customer or the user of the equipment or system should assure that it is used in such an environment.</p> |                   |  |
|---|-------------------|--|
| <b>Emissions test</b>   | <b>Compliance</b> | <b>Electromagnetic environment-guidance</b>  |
| RF emissions<br>CISPR 11  | Group 1           | Gima Vital Pro Monitor uses RF energy only for its internal function. Therefore, its RF emissions are very low and are not likely to cause any interference in nearby electronic equipment.                          |
| RF emissions<br>CISPR 11  | Class A           | Gima Vital Pro Monitor is suitable for use in all establishments other than domestic and those directly connected to the public low-voltage power supply network that supplies buildings used for domestic purposes. |
| Harmonic emissions<br>IEC61000-3-2  | Class A           |  |
| Voltage fluctuations/flicker emissions IEC61000-3-3   | Complies          |  |

**Table 2**  
**Guidance and manufacturer's declaration-electromagnetic immunity**  
**for all EQUIPMENT AND SYSTEMS**

| Gima Vital Pro Monitor is intended for use in the electromagnetic environment specified below. The customer or the user of the equipment or system should assure that it is used in such an environment. |   |   |  |
|--|---|---|--|
| <b>Immunity test</b>   | <b>IEC60601 test level</b>  | <b>Compliance level</b>   | <b>Electromagnetic environment -guidance</b>   |
| Electrostatic discharge(ESD)<br><b>IEC61000-4-2</b>  | ±6 kV contact<br>±8kV air   | ±6 kV contact<br>±8kV air   | Floors should be wood, concrete or ceramic tile. if floors are covered with synthetic material, the relative humidity should be at least 30%   |
| Electrical fast transient/burst<br><b>IEC61000-4-4</b>   | ±2kV for power Supply lines<br>±1 kV for input/output lines   | ±2kV for power Supply lines<br>±1 kV for input/output lines   | Mains power quality should be that of a typical commercial or hospital environment.  |
| Surge<br><b>IEC 61000-4-5</b>  | ±1kV line (s) to line(s)<br>±2kV line(s) to earth   | ±1kV differential mode<br>±2kV common mode  | Mains power quality should be that of a typical commercial or hospital environment.  |
| Voltage dips, short interruptions and voltage variations on power supply input lines<br><b>IEC61000-4-11</b>   | <5 % $U_T$<br>(>95 % dip in $U_T$ )<br>for 0,5 cycle<br><br>40 % $U_T$<br>(60 % dip in $U_T$ )<br>for 5 cycles<br><br>70 % $U_T$<br>(30 % dip in $U_T$ )<br>for 25 cycles<br><br><5 % $U_T$<br>(>95 % dip in $U_T$ )<br>for 5 s | <5 % $U_T$<br>(>95 % dip in $U_T$ )<br>for 0,5 cycle<br><br>40 % $U_T$<br>(60 % dip in $U_T$ )<br>for 5 cycles<br><br>70 % $U_T$<br>(30 % dip in $U_T$ )<br>for 25 cycles<br><br><5 % $U_T$<br>(>95 % dip in $U_T$ )<br>for 5 s | Mains power quality should be that of a typical commercial or hospital environment. If the user of the equipment or system requires continued operation during power mains interruptions, it is recommended that the equipment or system be powered from an uninterruptible power supply or a battery. |
| Power frequency (50Hz/60Hz) magnetic field<br><b>IEC61000-4-8</b>  | 3A/m  | 3A/m  | Power frequency magnetic fields should be at levels characteristic of a typical location in a typical commercial or hospital environment.  |
| NOTE $U_T$ is the a.c. mains voltage prior to application of the test level.   |   |   |  |

**Table 3**

**Guidance and manufacturer’s declaration – electromagnetic immunity-for EQUIPMENT and SYSTEM that are not LIFE-SUPPORTING**

| Gima Vital Pro Monitor is intended for use in the electromagnetic environment specified below. The customer or the user of Gima Vital Pro Monitor should assure that it is used in such an electromagnetic environment.  |                             |                  |  |
|--|-----------------------------|------------------|--|
| IMMUNITY test  | IEC 60601 test level        | Compliance level | Electromagnetic environment - guidance   |
| Conducted RF<br>IEC 61000-4-6  | 3 Vrms<br>150 kHz to 80 MHz | 3V               | Portable and mobile RF communications equipment should be used no closer to any part of Vital Signs Monitor, including cables, than the recommended separation distance calculated from the equation applicable to the frequency of the transmitter.<br><b>Recommended separation distance</b><br>$d = 1.2 \sqrt{P}$<br>$d = 1.2 \sqrt{P}$ 80 MHz to 800 MHz   |
| Radiated RF<br>IEC 61000-4-3   | 3 V/m<br>80 MHz to 2.5 GHz  | 3 V/m            | $d = 2.3 \sqrt{P}$ 800 MHz to 2,5 GHz<br>Where $P$ is the maximum output power rating of the transmitter in watts (W) according to the transmitter manufacturer and $d$ is the recommended separation distance in metres (m). <sup>b</sup><br>Field strengths from fixed RF transmitters, as determined by an electromagnetic site survey, <sup>a</sup> should be less than the compliance level in each frequency range. <sup>b</sup><br>Interference may occur in the vicinity of equipment marked with the following symbol.<br> |
| NOTE 1: At 80 MHz and 800 MHz, the higher frequency range applies.   |                             |                  |  |
| NOTE 2: These guidelines may not apply in all situations. Electromagnetic propagation is affected by absorption and reflection from structures, objects and people.  |                             |                  |  |
| a: Field strengths from fixed transmitters, such as base stations for radio (cellular / cordless) telephones and land mobile radios, amateur radio, AM and FM radio broadcast and TV broadcast cannot be predicted theoretically with accuracy. To assess the electromagnetic environment due to fixed RF transmitters, an electromagnetic site survey should be considered. If the measured field strength in the location in which Gima Vital Pro Monitor is used exceeds the applicable RF compliance level above, Gima Vital Pro Monitor should be observed to verify normal operation. If abnormal performance is observed, additional measures may be necessary, such as re-orienting or relocating Vital Signs Monitor. |                             |                  |  |
| b: Over the frequency range 150 kHz to 80 MHz, field strengths should be less than 3V/m.   |                             |                  |  |

**Table 4****Recommended separation distances between portable and mobile RF communications equipment and The equipment or system- for EQUIPMENT and SYSTEM that are not LIFE-SUPPORTING**

Gima Vital Pro Monitor is intended for use in an electromagnetic environment in which radiated RF disturbances are controlled. The customer or the user of the equipment or system can help prevent electromagnetic interference by maintaining a minimum distance between portable and mobile RF communications equipment (transmitters) and the equipment or system as recommended below, according to the maximum output power of the communications equipment.

| Rated maximum output power of transmitter<br>W | Separation distance according to frequency of transmitter<br>m |                                       |                                       |
|--|--|---------------------------------------|---------------------------------------|
|  | 150kHz to 80MHz<br>$d = 1.2 \sqrt{P}$                          | 80MHz to 800MHz<br>$d = 1.2 \sqrt{P}$ | 80MHz to 2,5GHz<br>$d = 2.3 \sqrt{P}$ |
| 0,01   | 0.12   | 0.12                                  | 0.23                                  |
| 0,1  | 0.38   | 0.38                                  | 0.73                                  |
| 1  | 1.2  | 1.2                                   | 2.3                                   |
| 10   | 3.8  | 3.8                                   | 7.3                                   |
| 100  | 12   | 12                                    | 23                                    |

For transmitters rated at a maximum output power not listed above, the recommended separation distance  $d$  in meters (m) can be determined using the equation applicable to the frequency of the transmitter, where  $p$  is the maximum output power rating of the transmitter in watts (W) according to the transmitter manufacturer.

NOTE 1: At 80 MHz and 800 MHz, the separation distance for the higher frequency range applies.

NOTE 2: These guidelines may not apply in all situations. Electromagnetic propagation is affected by absorption and reflection from structures, objects and people.

---

## Chapter 7 Packaging and Accessories

### 7.1 Packaging

The product is packed in high quality corrugated cartons with foam inside to protect the equipment against damage in the shipping and handling process.

**Weight:** Details see the indication on the outer package.

**Dimension:** 360(L)×320(W)×410(H) (mm)

### 7.2 Accessories Supplied

|                        |            |
|------------------------|------------|
| NIBP cuff              | One piece  |
| SpO <sub>2</sub> probe | One piece  |
| Temperature probe      | One piece  |
| Power cord             | One piece  |
| Grounding wire         | One piece  |
| User manual            | One copy   |
| Quality Certificate    | One copy   |
| Warranty               | Two copies |
| Packing list           | Two copies |

**Note:** The accessories are subject to change depending on the configuration of the monitor that you have ordered. Refer to the package for the detailed items and quantity.



---

## Chapter 8 Monitoring Parameter

### 8.1 ECG Monitoring

#### 8.1.1 How to Obtain High Quality ECG and Accurate Heart Rate Value

The electrocardiogram (ECG or EKG) is primarily a tool for evaluating the electrical events within the heart. The action potentials of cardiac-muscle cells can be viewed as batteries that cause charge to move throughout the body fluids. These currents represent the sum of the action potentials occurring simultaneously in many individual cells and can be detected by recording electrodes at the surface of the skin. The figure below shows the system of the heart.

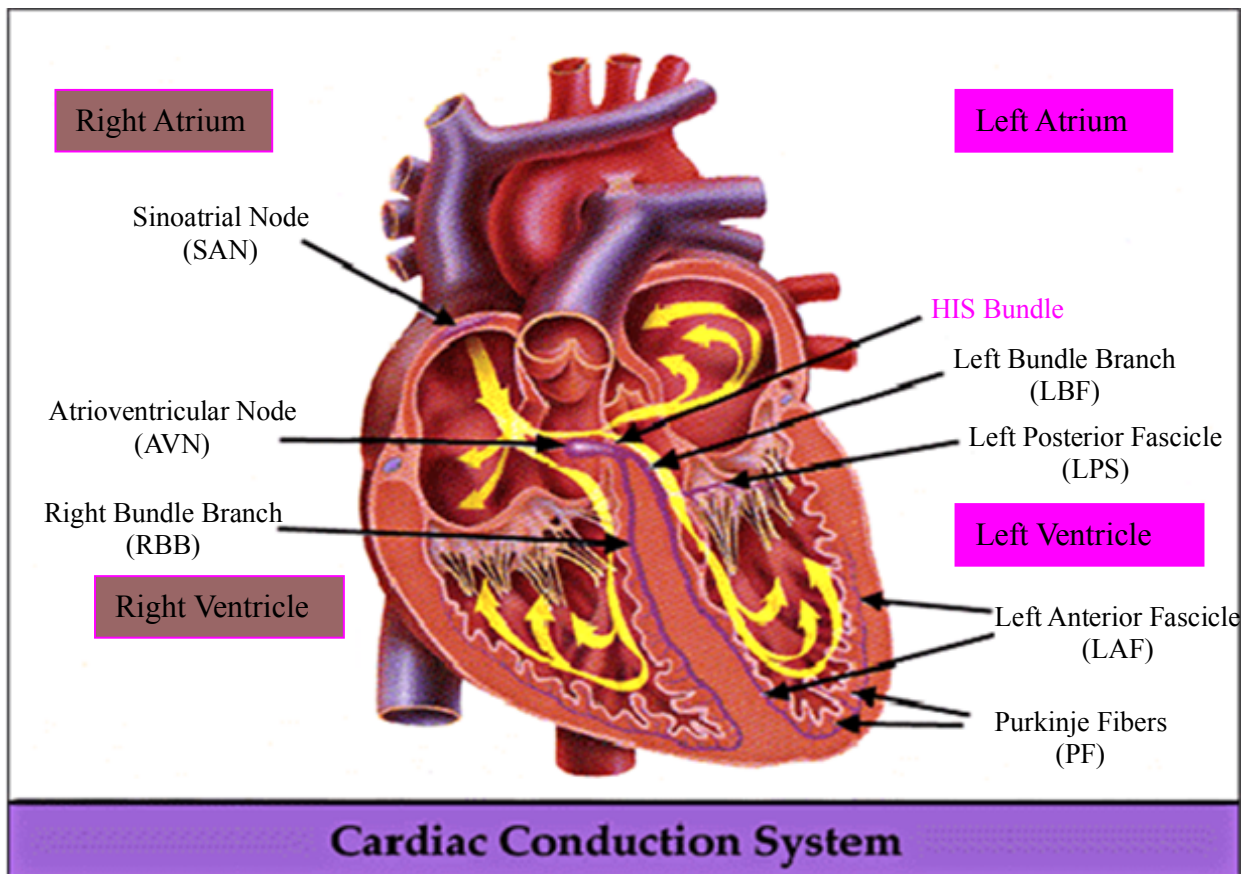

First of all, the hospital should be equipped with a 100~240V power supply system with a typical grounding wire. If big interference in ECG continues, connect one end of the grounding wire provided with this equipment to the grounding wire on the back panel of this monitor, and the other end to the special grounding wire, water pipe or radiator.

A common ECG plate electrode used together with this monitor has short shelf life. Generally, the shelf life is only one month after the package is opened. When outdated plate electrode is used, due to skin's contact impedance and big electrode potential, the chance of interference will be increased, and the ECG baseline will have an unstable inclination. Therefore, always use valid plate electrodes.

#### 8.1.2 Factors affecting ECG signal

- ✧ Interference from Electrosurgical Unit;
- ✧ Doesn't filter the interference waveform;
- ✧ Poor grounding;
- ✧ Electrodes are not placed properly;
- ✧ Use expired electrode or use disposable electrode repeatedly;

- 
- ◇ The skin placed electrode is unclean or poor contact caused by scurf and hair;
  - ◇ Electrode long-time used.

## 8.2 NIBP Monitoring

### 8.2.1 Measuring Principle

Blood pressure may be measured in an invasive way (whereby the sensor will be inserted into blood vessel directly) or a non-invasive way. The non-invasive way includes several methodologies, such as the Korotkoff Sound Method and oscillating method. The Korotkoff Sound Method is used as a conventional way, whereby stethoscope is used to measure the blood pressure. By the oscillating method, an inflation pump will fill the air, and release it slowly. A computer will record change of the cuff pressure when the air is released. With this record, the blood pressure value will be determined. First of all, make sure the signal quality judgment by computer meets the requirements of accurate calculation (such as sudden limb movement or cuff being hit during the measurement). If the answer is negative, give up the calculation. If the answer is positive, proceed with calculation of the blood pressure value.

As change of the blood pressure is recorded by electric sensor, which sensitivity is much higher than that of human ears, the oscillating method uses different definitions for measurement of diastolic pressure, mean arterial pressure and systolic pressure from the Korotkoff Sound Method. When the oscillating method is used, the circuit in the measuring apparatus will separate the amplitude of the cuff pressure from its change with pulsation. With the oscillating method, the blood pressure at the maximum amplitude of cuff pressure is defined as the mean arterial pressure. The blood pressure at amplitude of cuff pressure forward reduced according to proper proportion is defined as systolic pressure, while the blood pressure at amplitude of cuff pressure backward reduced according to proper proportion is defined as diastolic pressure. The maximum change of pulse pressure occurs at these two points. They are equivalent to the point with pulse sound and the point without pulse sound respectively in the Korotkoff Sound Method.

When the risk of invasive monitoring method outweighs its advantage of accuracy, non-invasive monitoring method shall be used.

#### **Comparison between blood pressure measuring methods**

To overcome the effect of human hearing variation and air release speed on measurement accuracy when the conventional Korotkoff Sound Method is used to take measure of blood pressure, people have been dedicated to study of automatic measurement of blood pressure. By now, automatic blood pressure measuring system based on the principle of oscillating method is mature. In practice, however, various problems are encountered, such as why the measures taken by the oscillating method is lower or higher than those taken by Korotkoff Sound Method? Why the measures are inclined to decline? Why, in some cases, no result is obtained in spite of the inflation actions? Why the measure values have big discreteness and even abnormal data in some cases? Why the SpO<sub>2</sub> waveforms may disappear suddenly? ...and so on. The following explanations are devised to give the answers.

#### **The Oscillating method vs. the Korotkoff Sound Method**

Blood pressure measurement by the oscillating method and Korotkoff Sound Method has good correlation with the invasive measurement. Notwithstanding, any of the non-invasive blood pressure measurements has its one-sidedness when it is compared to the invasive measurement. The oscillating method has its advantages over the Korotkoff Sound Method in less error, higher reliability and stability. Their differences may be reflected in the following aspects.

1. The measures by the Korotkoff Sound Method are liable to effect of human factors. For example, different people may have different sound judging ability, or different reactivity when listening to heart sound and reading mercury meter. The air release speed and subjectivity may also affect the judgment. By the oscillating method, the computation is accomplished by the computer, thus relieving the possibility of effect due to human factor.
2. With the Korotkoff Sound Method, the measure is taken on the basis of appearance and disappearance of heart sound. The air release speed and heart rate may have direct effect on the measurement accuracy. It also has the disadvantages of rapid air release and poor accuracy. In the contrast, with the oscillating method, the determination

---

is calculated on the basis of cuff pressure oscillatory waveform envelope, and the air release speed and heart rate has little effect on the measurement accuracy.

3. Statistics show that, when measuring the hypertension, the measure taken by the oscillating method is likely to be lower than that taken by the Korotkoff Sound Method. When measuring the hypotension, the measure taken by the oscillating method is likely to be higher than that by the Korotkoff Sound Method. But, it doesn't mean the advantages or disadvantages between the oscillating method and the Korotkoff Sound Method. Comparison with the results taken by more accurate method, let's say comparison of the invasive pressure result with the output value by the blood pressure measuring simulator, will show which method has more accurate results. In addition, higher or lower value should be a statistical concept. It is recommended those used to adopt the Korotkoff Sound Method use different physiological calibration for values determined by the oscillating method.
4. The studies have shown that the Korotkoff Sound Method has the worst accuracy when it comes to measurement of hypotension, while the oscillating method has worse accuracy when it comes to measurement of controlled hypertension relief.

### 8.2.2 Factors affecting NIBP measuring

- ✧ Select a cuff of appropriate size according to the size of the subject.
- ✧ The cuff width should be 2/3 of the length of the upper arm. The cuff inflation part should be long enough to wrap around 50-80% of the limb concerned.
- ✧ Prior to use of the cuff, empty the cuff of any residual air inside it to ensure accurate measurement.
- ✧ Locate the cuff in such a way that the mark "φ" is in the position where artery pulsates clearly for best effect.
- ✧ The lower part of the cuff should be 2cm above the elbow joint.
- ✧ Do not wrap the cuff over thick clothing;
- ✧ The patient should lie in bed or sit in a chair, in order for the cuff and heart to be at the same level and the most accurate measurement to be taken. Other postures may lead to inaccurate results;
- ✧ During measuring, do not move the arm or the cuff;
- ✧ The measuring interval shall longer than 2 minutes, in continuous measurement, too short interval may cause arm extrusion, blood quantity increases, then cause blood pressure increases.
- ✧ Keep the patient still and calm before and during measuring as the patient's state also affect the measuring result, e.g. when excited or anxious, their blood pressure will go up.
- ✧ Results will also be affected by the time of day, tending to be lower in the morning and higher in the evening;

### 8.2.3 Clinical Limitations and Contraindications

1. Serious angiospasm, vasoconstriction, or too weak pulse.
2. Extremely low or high heart rate or serious arrhythmia (especially auricular fibrillation) will lead to unreliable measurements or an inability to take a reading.
3. Patients connected to an artificial heart-lung machine.
4. Patient taking diuretics or vasodilators.
5. With patient suffering from major hemorrhage, hypovolemic shock and other conditions with rapid blood pressure change or when the body temperature is too low, the readings will not be reliable, as reduced peripheral blood flow will lead to reduced arterial pulsation.
6. Patient with hyperadiposis;

In addition, statistics show that 37% people report blood pressure difference of no less than 0.80kPa(6mmHg) between the left and right arms, and 13% people report difference of no less than 1.47kPa (11mmHg).

**Note: Some practitioners may report big discreteness or abnormal value of the blood pressure measures**

---

when the oscillating method is used. As a matter of fact, the so-called “big discreteness” must be a term in the sense of statistical significance of mass data. Abnormal data may be observed in some individual cases. It is normal in the scientific experiments. It may be caused by an apparent reason, or by an unknown factor in some cases. Such individual doubtful experimental data may be identified and eliminated using the special statistical technique. It is not a part of this manual. The practitioner may eliminate the apparently unreasonable data according to the experience.

## 8.3 SpO<sub>2</sub> Monitoring

### 8.3.1 Measuring Principle

Based on Lambert-Beer law, the light absorbance of a given substance is directly proportional with its density or concentration. When the light with certain wavelength emits on human tissue, the measured intensity of light after absorption, reflecting and attenuation in tissue can reflect the structure character of the tissue by which the light passes. Due to that oxygenated hemoglobin (HbO<sub>2</sub>) and deoxygenated hemoglobin (Hb) have different absorption character in the spectrum range from red to infrared light (600nm~1000nm wavelength), by using these characteristics, SpO<sub>2</sub> can be determined. SpO<sub>2</sub> measured by this monitor is the functional oxygen saturation -- a percentage of the hemoglobin that can transport oxygen. In contrast, hemoximeters report fractional oxygen saturation – a percentage of all measured hemoglobin, including dysfunctional hemoglobin, such as carboxyhemoglobin or methemoglobin.

### 8.3.2 Sources of interference for SpO<sub>2</sub> Measurement

- ✧ Intravascular dyes such as indocyanine green or methylene blue
- ✧ Exposure to excessive illumination, such as surgical lamps, bilirubin lamps, fluorescent lights, infrared heating lamps, or direct sunlight.
- ✧ Vascular dyes or external used colouring producta such as nail polish or tinted skin care
- ✧ Excessive patient movement
- ✧ Placement of a sensor on an extremity with a blood pressure cuff, arterial catheter, or intravascular line
- ✧ Exposure to a high pressure oxygen chamber
- ✧ Arterial occlusion proximal to the sensor
- ✧ Blood vessel contraction caused by peripheral vessel hyperkinesias or decreasing body temperature

### 8.3.3 Pathological reasons for low SpO<sub>2</sub> measurements

- ✧ Hypoxemia, functional lack of HbO<sub>2</sub>
- ✧ Pigmentation or abnormal oxyhemoglobin level
- ✧ Abnormal oxyhemoglobin variation
- ✧ Methemoglobin disease
- ✧ Sulfhemoglobinemia or arterial occlusion exists near sensor
- ✧ Obvious venous pulsations
- ✧ Peripheral arterial pulsation becoming weak
- ✧ Insufficient peripheral blood supply

### 8.3.4 Clinical Limitations

- ✧ As the measurement is taken on the basis of arteriole pulse, a substantial pulsating blood stream is required. For a patient with weak pulse, perhaps due to shock, low ambient/body temperature, major bleeding, or use of

---

vascular contracting drugs, the SpO<sub>2</sub> waveform (PLETH) will decrease. In this case, the measurement will be more sensitive to interference.

- ✧ For those with a substantial amount of staining dilution agent (such as methylene blue, indigo green and acid indigo blue), or carbon monoxide hemoglobin (COHb), or methionine (Me+Hb) or thiosalicylic hemoglobin, and some with icterus problem, the SpO<sub>2</sub> readings may be inaccurate.
- ✧ Drugs such as dopamine, procaine, prilocaine, lidocaine and butacaine may also be a major factor resulting in serious SpO<sub>2</sub> measurement errors.
- ✧ As the SpO<sub>2</sub> value serves as a reference value for judgment of anemic anoxia and toxic anoxia, the measurement result of some patients with serious anemia may also present as good SpO<sub>2</sub> value.

### 8.3.5 Points to be noted in SpO<sub>2</sub> and Pulse Measuring

- ✧ The finger should be properly placed (see the illustration to follow in this instruction manual), or else it may cause inaccurate measurement results.
- ✧ Make sure that the sensor is lined up so the red and infrared LEDs pass through the capillary arterial vessels .
- ✧ The SpO<sub>2</sub> sensor should not be used at a location or limb with an arterial or blood pressure cuff attached or receiving intravenous injection.
- ✧ Do not fix the SpO<sub>2</sub> sensor with adhesive tape, which may result in venous pulsation and consequential inaccurate measurement result of SpO<sub>2</sub>.
- ✧ Make sure the optical path is free from any obstacles such as adhesive tape.
- ✧ Excessive ambient light (such as fluorescent lights, infrared heaters and direct sunlight) may affect the measuring result.
- ✧ Strenuous activity of the patient or extreme electrosurgical interference may also affect the accuracy.
- ✧ Please do not use the SpO<sub>2</sub> sensor when having the MRI, or burn may be caused by faradism.
- ✧ Always observe the plethysmogram (waveform), which is auto-scaled within the range of 100. If the waveform is not smooth or is irregular, this may indicate that the SpO<sub>2</sub> readings are not accurate. If in doubt, rely on your clinical judgment, rather than the monitor readout.
- ✧ A functional tester cannot be used to assess the accuracy of the pulse oximeter monitor or a SpO<sub>2</sub> sensor. However, a functional tester, such as SpO<sub>2</sub> simulator can be used to check how accurately a particular pulse oximeter is reproducing the given calibration curve. Before testing the oximeter, please determine that the appropriate calibration curve is being used. If necessary, request this from the manufacturer and download it into the test device.

## 8.4 Temperature Monitoring (optional)

The sensor is thermo-resistor type (25°C 5kΩ) with constant micro current. Calculating the temperature measurement from the voltage. Temperature measurement can be obtained via two method: measure through body surface temperature and through the temperature inside the body cavity (with oral or rectal placement of the probe).

Normal value: body surface: 36.5°C~37°C; inside body cavity: 36.5°C~37.7°C

Notes:

- Attach the TEMP transducer/sensor to the patient; ensuring good contact with the skin if this method is chosen. Secure the sensor with adhesive tape.
- Especially for pediatric patient, they like sports, pay more attention to the transducer fixing.

---

## Chapter 9 Troubleshooting

### 9.1 No Display on the Screen

Shut down the monitor and unplug the power. Use a universal meter to check whether the outlet has proper voltage, if the power cable is in good condition, and that the power cable is properly connected with this apparatus or outlet. Remove the fuse from the back cover of the monitor, and make sure it is in good condition.

### 9.2 Excessive ECG Signal Interference or Too Thick Baseline

1. Check if the plate electrodes are properly located, and if valid plate electrodes are used.
2. Check whether the lead wires are inserted properly. If no ECG curve is displayed, check if the ECG lead wires are broken.
3. Make sure the mains outlet has standard grounding wire.
4. Check if the grounding wire of the apparatus is properly grounded.

### 9.3 No Blood Pressure and Pulse Oxygen Readings

1. Check that the blood pressure cuff is properly wrapped around the arm according to the operating instructions, that the cuff does not have a leak, that connections are secure on the cuff and tubing and that the inlet is closely connected with the NIBP jack on the side panel. Check that the LED of SpO<sub>2</sub> probe flashes and that the pulse oxygen probe is properly connected to the SpO<sub>2</sub> jack on the side panel.
2. If the problems still exist, please contact the local dealer.

### 9.4 Blank Print-out

1. Check whether the printing paper is installed the right way around (i.e. with the sensitive side upwards). Please reinstall it if necessary.
2. If the problems still exist, please contact the local dealer.

### 9.5 System Alarm

1. When the parameter value is higher or lower than the alarm limits, the alarm will sound. Please examine the condition of the patient and check whether the alarm limit values are set appropriately.
2. Probe off. Please check the connection of the probes.

**Note: If a problem arises with this machine in service, follow the instructions below to attempt to eliminate the problem first. If the attempt fails, contact the dealer in your local area or the manufacturer. Do not open the monitor casing without permission.**

---

# Chapter 10 Maintenance

## 10.1 Service and Examination

### 10.1.1 Daily Examination

Before using the monitor, the checks below should be carried out:

- Check the monitor for any mechanical damage;
- Inspect the exposed parts and the connectors, and the accessories;
- Examine all the functions of the monitor that are likely to be used for patient monitoring, and ensure that it is in good working condition;
- Make sure that the monitor is grounded properly.
- Pay close attention to the fluctuation of the local power supply voltage. A manostat is recommended when necessary.
- In the event that any damage to the monitor is found or any irregular function is detected and proven, do not use it.

### 10.1.2 Routine Maintenance

An annual maintenance inspection by qualified personnel, including functional and safety examination is recommended.. The designed life of this monitor is 5 years. In order to ensure a long service life, please pay attention to the required maintenance.

- ⚠ **Failure to carry out a satisfactory maintenance program for the monitor, may result in functional failures and harm the patient's safety and health.**
- ⚠ **In case of ECG leads damage or aging, please replace the lead.**
- ⚠ **If there is any indication of cable or transducer damage or deterioration, they must not be used.**
- 🔔 **The adjustable units in the monitor such as potentiometer should not be altered without permission to avoid unnecessary failures that may affect normal use. Maintenance repairs must only be carried out by suitably trained technicians.**

### 10.1.3 Battery Maintenance

- ⚠ **Please pay attention to the polarity of battery, and do NOT insert it into battery compartment with polarities reversed ;**
- ⚠ **Do NOT use batteries manufactured by other companies, which may cause damage to the device;**
- ⚠ **In order to avoid damaging the battery, do NOT use another power supply to charge the battery;**
- ⚠ **At the end of their lifetime, dispose of batteries in line with local guidelines.**
- ⚠ **Do not hit or strike with force;**
- ⚠ **Do not use this battery on other devices;**
- ⚠ **Do not use this battery below -10°C or above 40°C;**
- ⚠ **Dispose of the battery, the local law should be followed.**
- 🔔 **In order to maintain battery supply time and prolong battery lifetime, please charge the battery every one or two months if the monitor is not in regular use. Charge battery at least 12-15 hours every time. Before charging, run down the internal battery until the monitor turns off automatically to minimize memory effects. Charging time will be the same no matter whether the monitor is working or not. Charge fully**

---

before putting the monitor into storage.

- 🔔 Using a monitor powered solely by an internal battery power which has short charge power will cause the monitor turn off automatically when the battery is depleted.
- 🔔 Do NOT use batteries manufactured by other companies, which may cause damage to the device;(If battery is damaged, please replace with same type and specification battery marked by “CCC” or “CE” in time, or contact the company directly. )

### 10.1.4 Service

If the monitor malfunctions and you are not able to resolve an issue using the troubleshooting guide, please contact the supplier. Only qualified service engineers, specified by the manufacturer can perform maintenance and users are not permitted to repair the monitor or conduct maintenance by themselves.

## 10.2 Cleaning and Disinfection

- Keep the monitor free from dust.
- It is recommended to regularly clean the outer shell and screen of the monitor to keep it clean. Only a non-corrosive cleanser such as clear water is permitted.
- Wipe the surface of the monitor with a cloth slightly dampened with warm water and a mild, non-corrosive detergent or an alcohol impregnated wipe. Dry with a clean cloth or simply air-dry.
- The monitor can be sterilized and disinfected, please clean it first.
- 🔔 Switch off the monitor and disconnect the power cable before cleaning.
- 🔔 Do not let the liquid cleanser flow into the connector jack of the monitor to avoid damage.
- 🔔 Clean the exterior of the connector only.
- 🔔 Dilute the cleaning product in line with the manufacturer’s instructions.
- 🔔 Do not let any liquid flow into the shell or any other part of the monitor.
- 🔔 Do not leave any cleanser or disinfectant on the surface of the monitor.
- 🔔 Do not perform high pressure sterilization on the monitor.
- 🔔 Do not submerge any parts of the monitor or its accessories in the liquid.
- 🔔 If the monitor accidentally becomes wet, it should be thoroughly dried before use. The rear cover can be removed by a qualified service technician to verify absence of water.
- 🔔 Do not pour the disinfectant onto the monitor surface while disinfecting.
- 🔔

## 10.3 Cleaning and Disinfection of Accessories

It is recommended to clean the accessories (including sensor, leads and plugs) with a piece of gauze which has been soaked in 75% Alcohol or 70% Isopropanol before use.

- 🔔 Do not use damaged accessories.
- 🔔 Accessories can not be entirely immersed into water, alcohol or cleanser.
- 🔔 Do not use radial, steam or epoxyethane to disinfect accessories.
  - 🔔 Wipe off any remaining alcohol or isopropanol on the accessories after disinfection, for good maintenance can extend the life of accessories.



---

## 10.4 Storage

If the equipment will not be used for long period of time, wipe it clean and keep it in the packaging, in a dry and well ventilated place, free from dust and corrosive gases.

Storage environment: ambient temperature: -20~60°C

relative humidity: 10%~95%

atmosphere: 50kPa~107.4kPa

## 10.5 Transportation

This monitor should be transported by land (vehicle or railway) or air in accordance with the contractual terms. Do not hit or drop it with force.

---

## Chapter 11 Appendix

### 11.1 Prompt information explanations

|                             |   |
|-----------------------------|---|
| Mute C-D: XXX seconds       | Alarm silence count down: XXX seconds   |
| NIBP C-D: XXX seconds       | NIBP auto measuring cycle count down: XXX seconds   |
| TOUR C-D: XXX seconds       | Hemostat alert count down: XXX seconds  |
| Probe off                   | SpO <sub>2</sub> probe is off form the patient or disconnected from the device  |
| PR over limit               | PR value exceeds the high/low alarm limit   |
| SpO <sub>2</sub> over limit | SpO <sub>2</sub> value exceeds the high/low alarm limit   |
| SYS over limit              | Systolic pressure value exceeds the high/low alarm limit  |
| DIA over limit              | Diastolic pressure value exceeds the high/low alarm limit   |
| MAP over limit              | MAP value exceeds the high/low alarm limit  |
| NIBP error 1#               | Sensor or other hardware error  |
| NIBP error 2#               | Very weak signal because of the cuff, or the patient has very weak pulse  |
| NIBP error 3#               | Blood pressure amplifier overflow due to excessive movement   |
| NIBP error 4#               | Leaking during the pneumatic device testing   |
| Cuff error                  | Cuff is not wrapped correctly, or is not connected  |
| NIBP error 5#               | Hardware fault of NIBP module   |
| Air leak                    | Pneumatic part, tube or the cuff leak air   |
| NIBP over range             | The measurement range exceeds 255mmHg (for neonates: over 135 mmHg)   |
| Over motion                 | Excessive movement or noise during inflation and measurement. Another measurement will be taken.  |
| Over pressure               | Cuff pressure exceeds the safety limit value of software. (limit for adults: 290mmHg; limit for pediatric: 145mmHg)<br>Or caused by cuff extrusion or flapping cuff with force. |
| NIBP timeout                | Adult measurement is more than 120 seconds, neonate measurement is more than 90 seconds.  |

## 11.2 Factory Default Alarming Values and Setup Range

The factory default alarming value:

| Parameter \ Mode |            | Adult   | Pediatric | Neonate |
|------------------|------------|---------|-----------|---------|
|                  |            |         |           |         |
| HR               | High limit | 180bpm  | 200bpm    | 220bpm  |
|                  | Low limit  | 40bpm   | 50bpm     | 50bpm   |
| SYS              | High limit | 180mmHg | 130mmHg   | 110mmHg |
|                  | Low limit  | 60mmHg  | 50mmHg    | 50mmHg  |
| DIA              | High limit | 120mmHg | 90mmHg    | 90mmHg  |
|                  | Low limit  | 50mmHg  | 40mmHg    | 30mmHg  |
| MAP              | High limit | 160mmHg | 110mmHg   | 100mmHg |
|                  | Low limit  | 50mmHg  | 40mmHg    | 30mmHg  |
| SpO <sub>2</sub> | High limit | 100%    | 100%      | 100%    |
|                  | Low limit  | 90%     | 85%       | 85%     |
| Pulse rate       | High limit | 180bpm  | 200bpm    | 220bpm  |
|                  | Low limit  | 40bpm   | 50bpm     | 50bpm   |
| TEMP             | High limit | 39.0°C  | 39.0°C    | 39.0°C  |
|                  | Low limit  | 35.0°C  | 35.0°C    | 35.0°C  |

The high and low limits setting range:

| Parameter \ Mode |            | Adult         | Pediatric     | Neonate       | Setting Step |
|------------------|------------|---------------|---------------|---------------|--------------|
| HR               | High limit | (1~350) bpm   | (1~350) bpm   | (1~350) bpm   | 1 bpm        |
|                  | Low limit  | (0~349) bpm   | (0~349) bpm   | (0~349) bpm   | 1 bpm        |
| SYS              | High limit | (30~280) mmHg | (30~200) mmHg | (30~135) mmHg | 1 mmHg       |
|                  | Low limit  | (29~279) mmHg | (29~199) mmHg | (29~134) mmHg | 1 mmHg       |
| DIA              | High limit | (11~232) mmHg | (11~150) mmHg | (11~100) mmHg | 1 mmHg       |
|                  | Low limit  | (10~231) mmHg | (10~149) mmHg | (10~99) mmHg  | 1 mmHg       |
| MAP              | High limit | (21~242) mmHg | (21~165) mmHg | (21~110) mmHg | 1 mmHg       |
|                  | Low limit  | (20~241) mmHg | (20~164) mmHg | (20~109) mmHg | 1 mmHg       |
| SpO <sub>2</sub> | High limit | 1~100%        | 1~100%        | 1~100%        | 1%           |
|                  | Low limit  | 0~99%         | 0~99%         | 0~99%         | 1%           |
| Pulse rate       | High limit | (1~300) bpm   | (1~350) bpm   | (1~350) bpm   | 1 bpm        |
|                  | Low limit  | (0~299) bpm   | (0~349) bpm   | (0~349) bpm   | 1 bpm        |
| TEMP             | High limit | (0.1~60) °C   | (0.1~60) °C   | (0.1~60) °C   | 0.1°C        |
|                  | Low limit  | (0~59.9)°C    | (0~59.9)°C    | (0~59.9)°C    | 0.1°C        |

Note: it's limited for the high/low alarm setting value, which ensure that the high-limit setting value will not less than (or equal to) that of the low-limit setting value. See the above table for detailed setting step.

---

### 11.3 Abbreviation of arrhythmia

| Type | Abbreviation  | Full name                                      |
|------|---------------|--|
| 1    | ECG TACHY     | Tachycardia                                    |
| 2    | ECG BRADY     | Bradycardia                                    |
| 3    | ECG ARREST    | Cardiac Arrest                                 |
| 4    | MISS BEAT     | Missing Beat                                   |
| 5    | VE EARLY      | Ventricular Premature Contraction (VPC)        |
| 6    | SVE EARLY     | Supra-ventricular Premature Contraction (SVPC) |
| 7    | VE COUPLET    | Ventricular Couplet                            |
| 8    | SVE COUPLET   | Supra-ventricular Couplet                      |
| 9    | VE RUN        | Ventricular Run                                |
| 10   | SVE RUN       | Supra-ventricular Run                          |
| 11   | VE SHORT RUN  | Ventricular Short Run                          |
| 12   | SVE SHORT RUN | Supra-ventricular Short Run                    |
| 13   | VE BIGEMINY   | Ventricular Bigeminy                           |
| 14   | SVE BIGEMINY  | Supra-ventricular Bigeminy                     |
| 15   | VE TRIGEMINY  | Ventricular Trigeminy                          |
| 16   | SVE TRIGEMINY | Supra-ventricular Trigeminy                    |
| 17   | VE INSERT     | Ventricular Insert                             |
| 18   | SVE INSERT    | Supra-ventricular Insert                       |
| 19   | VE RONT       | Ventricular RonT                               |
| 20   | SVE RONT      | Supra-ventricular RonT                         |

---

## 11.4 Instructions for SpO<sub>2</sub> Probe

### Instructions for Neonate SpO<sub>2</sub> Y-type Sensor

#### Intended Use

Must be used with a compatible patient monitor or a pulse oximeter device. The sensor is intended to be used for continuous, non-invasive functional arterial oxygen saturation (SpO<sub>2</sub>) and pulse rate monitoring for neonates (1-3 kg).

#### Contraindications

This sensor is contraindicated for use on active patients or for prolonged use.

#### Instructions for Use

- 1) Insert the two sensor tips into the slots on the rubber wrap (A); place the sensor on the neonate's foot, or place the sensor on the neonate's palm (B), and wrap the rubber belt around the foot/palm and tighten accordingly .
- 2) Plug the sensor into the oximeter and verify proper operation as described in the oximeter operator's manual.
- 3) Inspect the monitoring site every 4 hours for skin integrity.

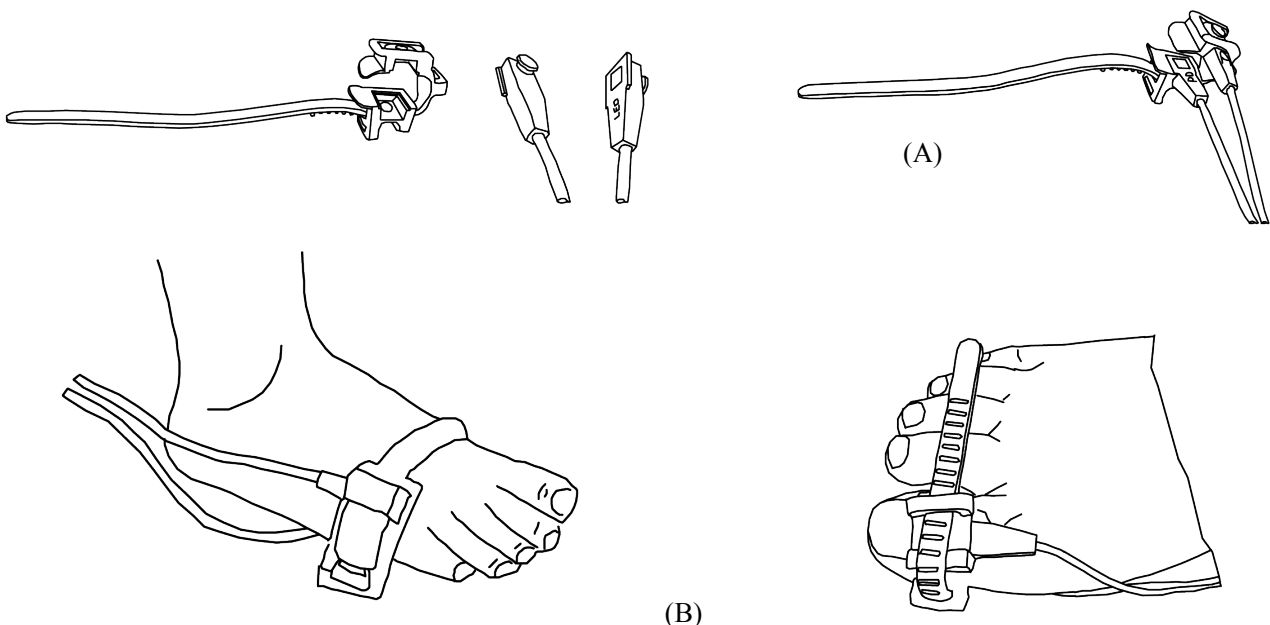

#### Cleaning & Disinfection

Unplug the sensor before cleaning or disinfecting. Surface-clean sensor and cable with a soft gauze pad by saturating it with a solution such as 70% isopropyl alcohol. If low-level disinfection is required, use a 1:10 bleach solution.

#### Warnings

- 1) Some factors may affect the accuracy of saturation measurements. Such factors include: excessive
- 2) patient movement, fingernail polish, use of intravascular dyes, excessive light, poorly perfused finger, extreme finger sizes or improper placement of the sensor.
- 3) The sensor must be checked for skin integrity at least every 4 hours as individual skin conditions affects the ability of the skin to tolerate sensor placement, it may be necessary to change the sensor site.
- 4) Do not use NIBP or other constructing instruments on same appendage as sensor for blood flow interrupted by NIBP cuff or circulatory patient condition will result in no pulse found or loss of pulse.
- 5) Do not use the sensor during MRI scanning. Carefully route cables to reduce the possibility of patient entanglement or strangulation.
- 6) Do not alter or modify the sensor. Alterations or modifications may affect performance or accuracy.
- 7) Do not use the sensor if the sensor or the sensor cable appears damaged.

**Caution: Do not sterilize by irradiation steam, or ethylene oxide.**

---

## Instructions for Pediatric SpO<sub>2</sub> Finger Clip Sensor

### Intended Use

Must be used with a compatible patient monitor or a pulse oximeter device. The sensor is intended to be used for continuous, non-invasive functional arterial oxygen saturation (SpO<sub>2</sub>) and pulse rate monitoring for pediatric patients weighing between 10~40kg.

### Contraindications

This sensor is contraindicated for use on active patients or for prolonged use.

### Instructions for Use

- 1) With the upper and lower jaws open, place an index finger evenly on the base of the clip. Push the finger tip against the stop so that it is over the sensor window . If an index finger cannot be positioned correctly, or is not available, other fingers can be used.
- 2) Note: When selecting a sensor site, priority should be given to an extremity free of an arterial catheter, blood pressure cuff, or intravascular infusion line.
- 3) Spread open the rear tabs of the sensor to provide even force over the length of the pads .
- 4) The sensor should be oriented in such a way that the cable is positioned along the top of the hand .
- 5) Plug the sensor into the oximeter and verify proper operation as described in the oximeter operator's manual.
- 6) Inspect the monitoring site every 4 hours for skin integrity.
- 7) Before each use, surface-clean sensor and cable with a soft gauze pad by saturating it with a solution such as 70% isopropyl alcohol. If low-level disinfection is required, use a 1:10 bleach solution.

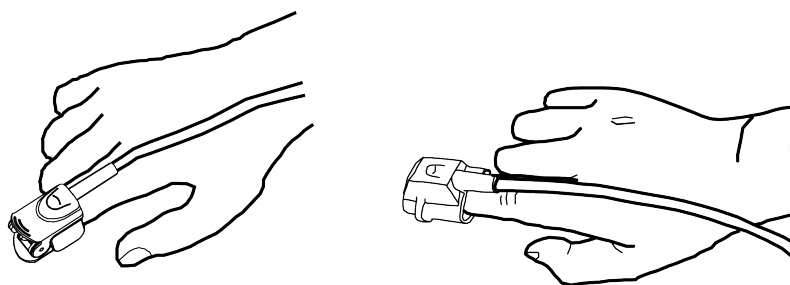

**Caution: Do not sterilize by irradiation steam, or ethylene oxide.**

### Warnings

- 1) Some factors may affect the accuracy of saturation measurements. Such factors include: excessive patient movement, fingernail polish, use of intravascular dyes, excessive light, poor blood perfusion in the finger, extreme finger sizes or improper placement of the sensor.
- 2) Using the sensor in the presence of bright lights may result in inaccurate measurements. In such cases, cover the sensor site with an opaque material.
- 3) The sensor must be moved to a new site at least every 4 hours. Because individual skin condition affects the ability of the skin to tolerate sensor placement, it may be necessary to change the sensor site more frequently with some patients. If skin integrity changes, move the sensor to another site.
- 4) Do not apply tape to secure the sensor in place or to tape it shut; venous pulsation may lead to inaccurate saturation measurements.
- 5) Do not immerse sensor as it causes short.
- 6) Do not use NIBP or other constructing instruments on same appendage as sensor for blood flow interrupted by NIBP cuff or circulatory patient condition will result in no pulse found or loss of pulse.
- 7) Do not use the sensor or other oximetry sensors during MRI scanning.
- 8) Carefully route cables to reduce the possibility of patient entanglement or strangulation.
- 9) Do not alter or modify the sensor. Alterations or modifications may affect performance or accuracy.
- 10) Do not use the sensor if the sensor or the sensor cable appears damaged.

---

## Instructions for Adult SpO<sub>2</sub> Finger Rubber Sensor

### Intended Use

Must used with a compatible patient monitor or a pulse oximeter device. This SpO<sub>2</sub> sensor is intended to be used for continuous, non-invasive functional arterial oxygen saturation (SpO<sub>2</sub>) and pulse rate monitoring for patients weighing greater than 50kg.

### Contraindications

This sensor is contraindicated for use on active patients or for prolonged use.

### Instructions for Use

- 1) Hold the sensor with its opening towards the patient's index finger (A). The sensor should be oriented in such a way that the sensor side with a finger tip sign is positioned on the top.
- 2) Insert the patient's index finger into the sensor until the fingernail tip rests against the stop at the end of the sensor. Adjust the finger to be placed evenly on the middle base of the sensor. Direct the cable along the top of the patient's hand. Apply adhesive tape to secure the cable (B). If an index finger cannot be positioned correctly, or is not available, other fingers can be used.
- 3) Plug the sensor into the oximeter and verify proper operation as described in the oximeter operator's manual.
- 4) Inspect the monitoring site every 4 hours for skin integrity.

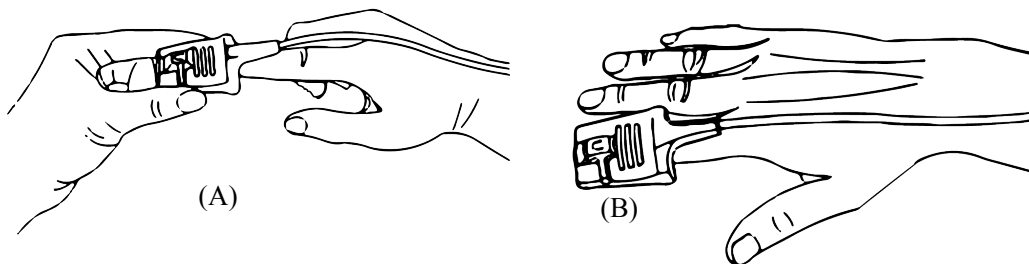

### Cleaning & Disinfection

Unplug the sensor before cleaning or disinfecting. Surface-clean sensor and cable with a soft gauze pad by saturating it with a solution such as 70% isopropyl alcohol. If low-level disinfection is required, use a 1:10 bleach solution.

**Caution: Do not sterilize by irradiation steam, or ethylene oxide.**

### Warnings

- 1) This sensor is for use only with compatible patient monitors or pulse oximeter devices. Use of this sensor with instruments other than compatibles may result in improper performance.
- 2) Some factors may affect the accuracy of saturation measurements. Such factors include: excessive patient movement, fingernail polish, use of intravascular dyes, excessive light, poorly perfused finger, extreme finger sizes or improper placement of the sensor.
- 3) The sensor site must be checked for skin integrity at least every 4 hours. Because individual skin condition affects the ability of the skin to tolerate sensor placement, it may be necessary to change the sensor to another finger.
- 4) Do not use NIBP or other constraining instruments on same appendage as sensor for blood flow interrupted by NIBP cuff or circulatory patient condition will result in no pulse found or loss of pulse. Do not use the sensor during MRI scanning.
- 5) Carefully route cables to reduce the possibility of patient entanglement or strangulation.
- 6) Do not alter or modify the sensor. Alterations or modifications may affect performance or accuracy.
- 7) Do not use the sensor if the sensor or the sensor cable appears damaged.

---

## Instructions for Adult SpO<sub>2</sub> Finger Clip Sensor

### Intended Use

Must be used with a compatible patient monitor or a pulse oximeter device. The sensor is intended to be used for continuous, non-invasive functional arterial oxygen saturation (SpO<sub>2</sub>) and pulse rate monitoring for patients weighing greater than 40kg.

### Contraindications

This sensor is contraindicated for use on active patients or for prolonged use.

### Instructions for Use

- 1) With the upper and lower jaws open, place an index finger evenly on the base of the clip. Push the finger tip against the stop so that it is over the sensor window . If an index finger cannot be positioned correctly, or is not available, other fingers can be used.
- 2) Note: When selecting a sensor site, priority should be given to an extremity free of an arterial catheter, blood pressure cuff, or intravascular infusion line.
- 3) Spread open the rear tabs of the sensor to provide even force over the length of the pads .
- 4) The sensor should be oriented in such a way that the cable is positioned along the top of the hand .
- 5) Plug the sensor into the oximeter and verify proper operation as described in the oximeter operator's manual.
- 6) Inspect the monitoring site every 4 hours for skin integrity.
- 7) Before each use, surface-clean sensor and cable with a soft gauze pad by saturating it with a solution such as 70% isopropyl alcohol. If low-level disinfection is required, use a 1:10 bleach solution.

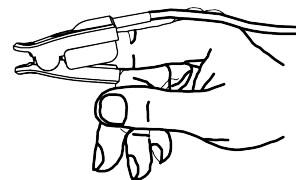
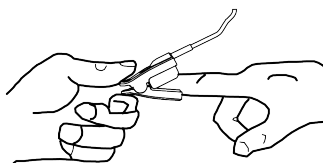

**Caution: Do not sterilize by irradiation steam, or ethylene oxide.**

### Warnings













- 1) Some factors may affect the accuracy of saturation measurements. Such factors include: excessive patient movement, fingernail polish, use of intravascular dyes, excessive light, poorly perfused finger, extreme finger sizes or improper placement of the sensor.
- 2) Using the sensor in the presence of bright lights may result in inaccurate measurements. In such cases, cover the sensor site with an opaque material.
- 3) The sensor must be moved to a new site at least every 4 hours. Because individual skin condition affects the ability of the skin to tolerate sensor placement, it may be necessary to change the sensor site more frequently with some patients. If skin integrity changes, move the sensor to another site.
- 4) Do not apply tape to secure the sensor in place or to tape it shut; venous pulsation may lead to inaccurate saturation measurements.
- 5) Do not immerse sensor as it causes short.
- 6) Do not use NIBP or other constructing instruments on same appendage as sensor for blood flow interrupted by NIBP cuff or circulatory patient condition will result in no pulse found or loss of pulse.
- 7) Do not use the sensor or other oximetry sensors during MRI scanning.
- 8) Carefully route cables to reduce the possibility of patient entanglement or strangulation.
- 9) Do not alter or modify the sensor. Alterations or modifications may affect performance or accuracy.
- 10) Do not use the sensor if the sensor or the sensor cable appears damaged.

**We offer a 6-month warranty against manufacturing defects for the SpO<sub>2</sub> sensors mentioned above in its undamaged condition.**



If you have any question regarding any of SpO<sub>2</sub> sensor instructions, please contact your local dealer.

**Explanation of Symbols in the Monitor**

|   |   |
|---|---|
|    | Caution: read instructions (warnings) carefully     |
|    | Serial number                                       |
|    | WEEE disposal                                       |
|    | Keep in a cool, dry place                           |
|    | Manufacturer  |
|   | Date of manufacture                                 |
|  | Authorized representative in the European community |
|  | Defibrillation-proof type BF applied part           |
|  | Follow instructions for use                         |
|  | Defibrillation-proof type CF applied part           |
|  | Medical Device complies with Directive 93/42/EEC    |
|  | Product code  |
|  | Keep away from sunlight                             |



**Disposal:** The product must not be disposed of along with other domestic waste. The users must dispose of this equipment by bringing it to a specific recycling point for electric and electronic equipment.

**GIMA WARRANTY TERMS**

The Gima 12-month standard B2B warranty applies.